



Service manual
CDP 40-50-70 / CDP 40T-50T-70T Dehumidifier



31026237

Rev. 1.1 • 02-03-2026

Table of contents

Introduction	3
Symbols used in the operating instructions	4
Safety	5
Product description	6
Scope of delivery and unpacking	6
Overall product description	7
Component description	8
Installation	10
Wall mounting	10
Power connection	14
Operation	18
Control panel	18
Maintenance and troubleshooting	22
Preventive maintenance activities	22
Updating the software	24
Log files	25
Troubleshooting	26
Annex	32
Technical data	32
Circuit diagrams	33
Disposal	36
Disassembly	36
Spare parts	37
How to order	37
Declaration of conformity (EU)	38

Introduction

Overview

This is the manual for the Dantherm dehumidifiers CDP(-T) 40-50-70.

User groups

User groups for these operating and service instructions are:

- Operators using the unit as intended.
- Qualified personnel (e.g. refrigeration technicians, installers, service technicians) who properly install and maintain the unit.

Accessibility

The unit may be placed where it is accessible to the general public.

Copyright

No part of this manual may be reproduced without the prior written permission of Dantherm.

Recycling

This unit is designed to provide a long service life. At the end of its service life, the unit must be recycled in accordance with national regulations and with high environmental protection considerations. The dehumidifier contains R454C refrigerant and compressor oil.

Reservations

Dantherm reserves the right to make changes and improvements to the product and the manual at any time without any obligation to give prior notice.

Quality Management System

Dantherm has implemented a quality management system in accordance with EN/ISO9001. The system is supplemented with an environmental management system in accordance with EN/ISO14001.

Storage and transportation

Storage and transportation of a refrigerant system containing a flammable refrigerant must comply with all applicable local occupational health and safety and environmental legislation.

Abbreviations in this document

The following abbreviations are used in this manual:

Abbreviation	Description
HP	High pressure
LP	Low pressure
TEV	Thermostatic expansion valve

Symbols used in the operating instructions

In these operating instructions, particularly important text passages are highlighted with signal words and symbols that are described below.

Signal words

 **DANGER**

...indicates a hazard which, if not avoided, will result in death or serious injury.

 **WARNING**

...indicates a hazard which, if not avoided, could result in death or serious injury.

 **CAUTION**

...indicates a hazard which, if not avoided, could result in a minor or moderate injury.

NOTICE

...indicates important information (e.g. property damage) but does not indicate hazards.

INFO

...information marked with this symbol helps you to carry out your tasks quickly and safely.

Hazard symbols



This symbol is used to warn you of potential risk of injuries. Follow all safety instructions indicated in the manual next to the warning triangle to avoid potential injury or death.



Electrical voltage

This symbol indicates that there are dangers to the life and health of persons due to electrical voltage when handling the system.



Protective gloves

This symbol indicates that it is required to wear protective gloves when performing a specific operation.



You can be severely injured by an electric shock

This symbol indicates that the unit should be disconnected.



Sharp edges

This symbol indicates that the cabinet of the unit may have sharp edges on which you can cut yourself.



Very hot and very cold parts inside

There may be very hot or very cold parts inside the units on which you can easily burn yourself.



Heavy equipment

Back strain/injury possible
Several persons required to lift equipment

Safety



Note! Read carefully before use. Keep for future reference.

It is the responsibility of the operator to read and understand this manual and other information provided and to apply the correct operating procedures.

Read the entire manual before starting up the unit for the first time. It is important to be familiar with the correct operating procedures for the unit and all related safety precautions to avoid the risk of personal injury and/or property damage.

Safety instructions



The following safety instructions must be observed:

- Ensure that all electric cables outside of the unit are protected from damage (e.g. caused by animals). Never use the unit if electric cables are damaged!
- Only install the unit in accordance with the national regulations for electrical connection.
- Observe the operating conditions specified in the "Technical data" chapter.
- Do not use the unit in potentially explosive rooms or areas and do not install it there.
- Do not cover any air intakes or outlets at any point – except with accessories intended for this purpose.
- Never immerse the device in water

Intended use

The dehumidifier is designed to remove moisture from the air in warehouses and similar spaces. The humid air is sucked in, condenses, and is fed back into the room as dry air. The unit is designed to be used under the operating conditions specified in the technical data.

Foreseeable misuse

Any operation other than as described in this manual is prohibited. Non-observance renders all claims for liability and guarantee null and void.

If any unauthorised modifications are made, any claims for liability and guarantee are rendered null and void.

Personnel qualifications

This appliance must only be operated by qualified (trained) personnel, and any repair of the cooling circuit or electrical system must be carried out by qualified personnel only; failure to do so may result in personal injury or damage to the equipment. The appliance is not intended for use by persons (including children) with reduced physical, sensory or mental capabilities, or by persons lacking experience and knowledge, unless they have been given supervision or instruction concerning its use by a person responsible for their safety.

Stage of life	Activity	Target group
Installation		Qualified personnel
Operation		Qualified personnel
Maintenance	Monthly maintenance activities	Operating personnel
	Annual maintenance activities	Qualified personnel
Repair		Qualified personnel

WARNING

Do not use any methods to accelerate the defrosting process or to clean the unit other than those specifically recommended by the manufacturer.

The appliance must be stored in a room free from continuously operating ignition sources, such as open flames, gas appliances in operation, or electric heaters in use.

Do not pierce or burn the appliance.

Be aware that refrigerants may be odourless.

Product description

Scope of delivery and unpacking

Check the scope of delivery for transport damage during unpacking:

1. Report obvious, external damages to the carrier, packaging company, post office, etc. immediately upon receipt and note the damage in the consignment or transport documents.
2. Remove the packaging completely (without using a knife) and dispose of the packaging material according to the local regulations.
3. Check the content of the box.
4. If you notice any transport damage after unpacking the unit or if the delivery is incomplete, contact the responsible sales representative or specialist dealer immediately.

The following parts are included in the scope of delivery:

Scope of delivery

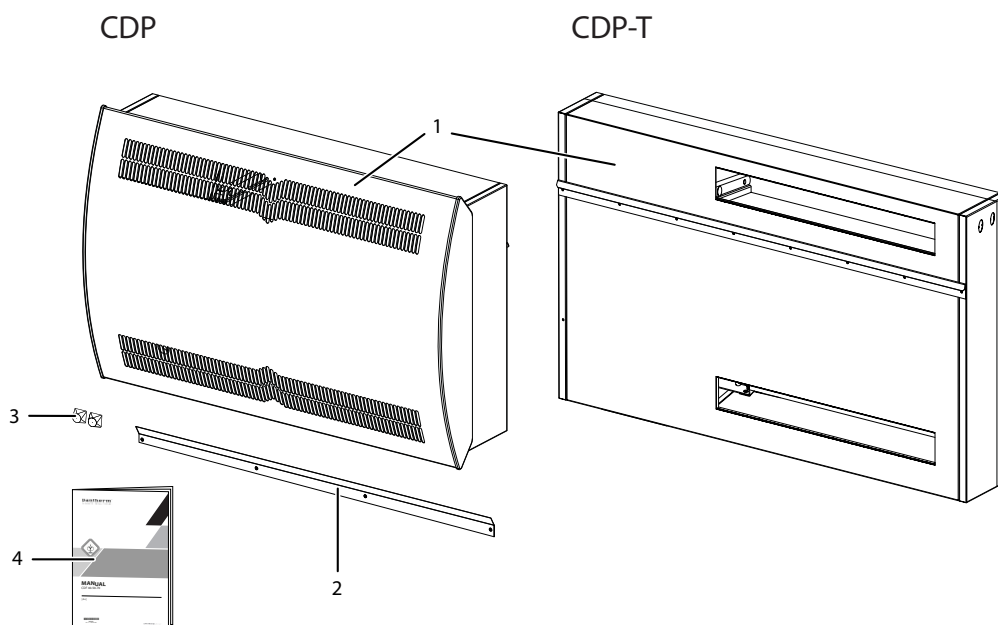

Fig. 1: Scope of delivery

1. Dehumidifier
2. Wall rail
3. Spacers x 2
4. Service instructions

Overall product description

The unit is designed to provide for a long and efficient operation. It is made of high-quality materials. The production process is subject to constant quality control.

Functioning principle

The dehumidifiers work according to the condensation principle. Humid room air is drawn into the unit by a fan. The air flows through the evaporator and is cooled down to below the dew point. This causes the water vapour to condense into water, which is drained. The dry air is then passed through the condenser, where it is heated and returned to the room. As a result of the latent heat generated in the condensation process and the compressor energy, the extract air temperature to the room is about 5 °C higher than the air drawn in from the room.

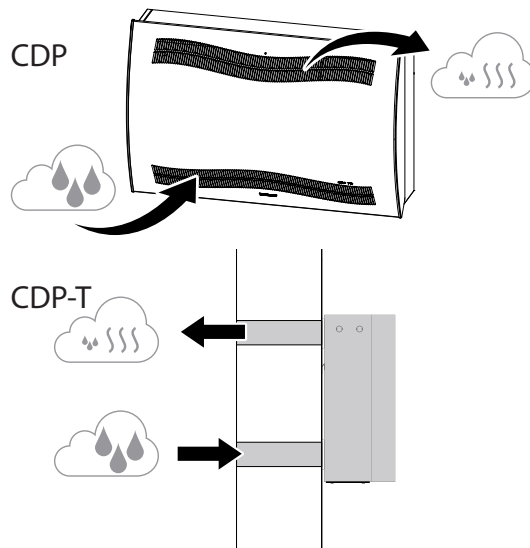

Fig. 2: Functioning principle

Safety shutdown

If the temperature in the unit rises above 55 °C, the compressor stops automatically to prevent damage. As soon as the temperature in the unit is low enough, dehumidification will continue.

This may be the case, for example, in the event of a fan failure or if the room temperature exceeds 36 °C.

Overload protection

To protect the compressor from overload, there is a timer built in to prevent the dehumidifier from starting more than 10 times per hour. This means that there is at least 6 minutes between each start-up.

Fan control

When the unit is started by the hygostat, the compressor and fan(s) also start at the same time.

For CDP/CDP-T 40-50-70 only:

To determine the humidity level, the fan(s) are started up by the dehumidifier once an hour for a period of one minute.

- If the humidity level is above the selected setpoint, the unit starts dehumidifying.
- If the humidity level is below the selected setpoint, the unit remains switched off and determines the humidity level again after one hour.

Defrost function

The unit is equipped with an intelligent defrost function. The unit monitors the temperature of the evaporator. When the temperature has been below a certain temperature for a certain period of time, the unit will switch to active defrosting. The fans will stop and the solenoid valve will open.

The hot gas can now pass through the evaporator. As soon as the evaporator has reached the desired temperature again, the solenoid valve will close and dehumidification will continue.

Component description

CDP models

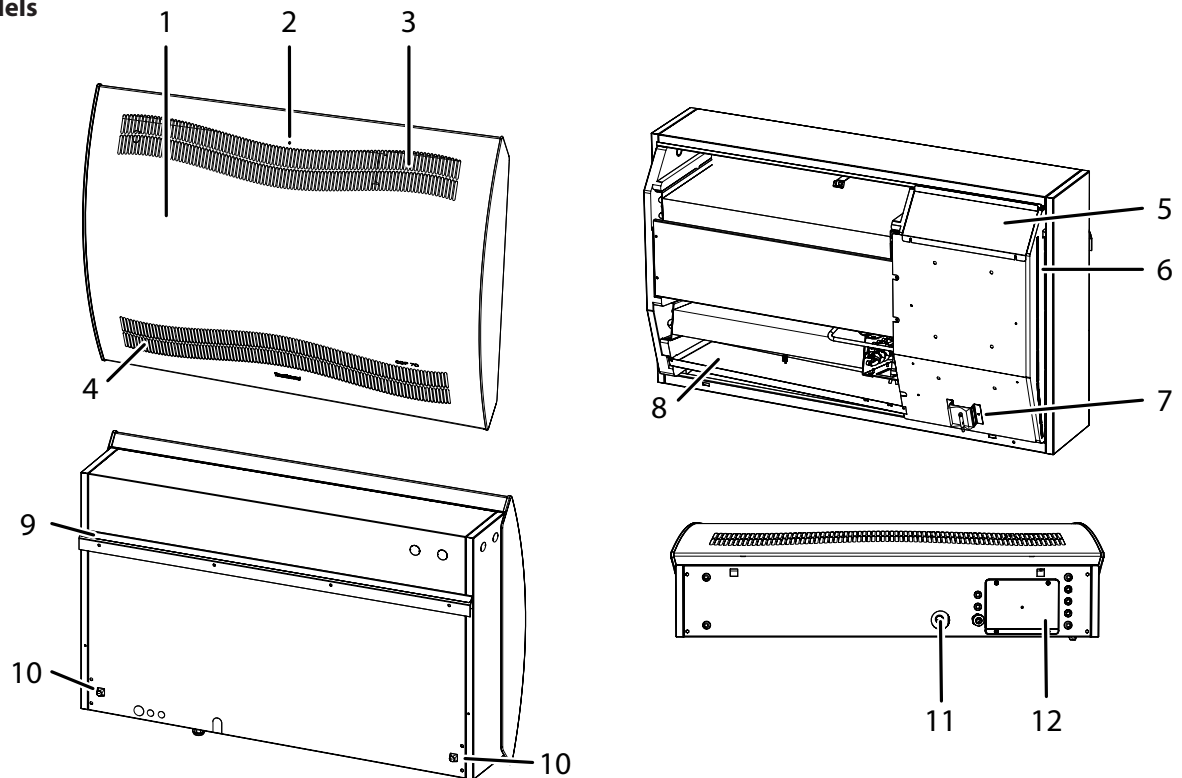

Fig 3: Components - CDP models

- | | |
|---------------------------------------|---------------------------------------|
| 1 Front cover | 7 Humidity sensor |
| 2 LED light | 8 Drip tray |
| 3 Air outlet | 9 Wall rail |
| 4 Air inlet | 10 Wall mounting spacers |
| 5 Control panel (behind the cover) | 11 Water drain |
| 6 Cable groove (for accessories only) | 12 Power connection (behind the flap) |

CDP-T models

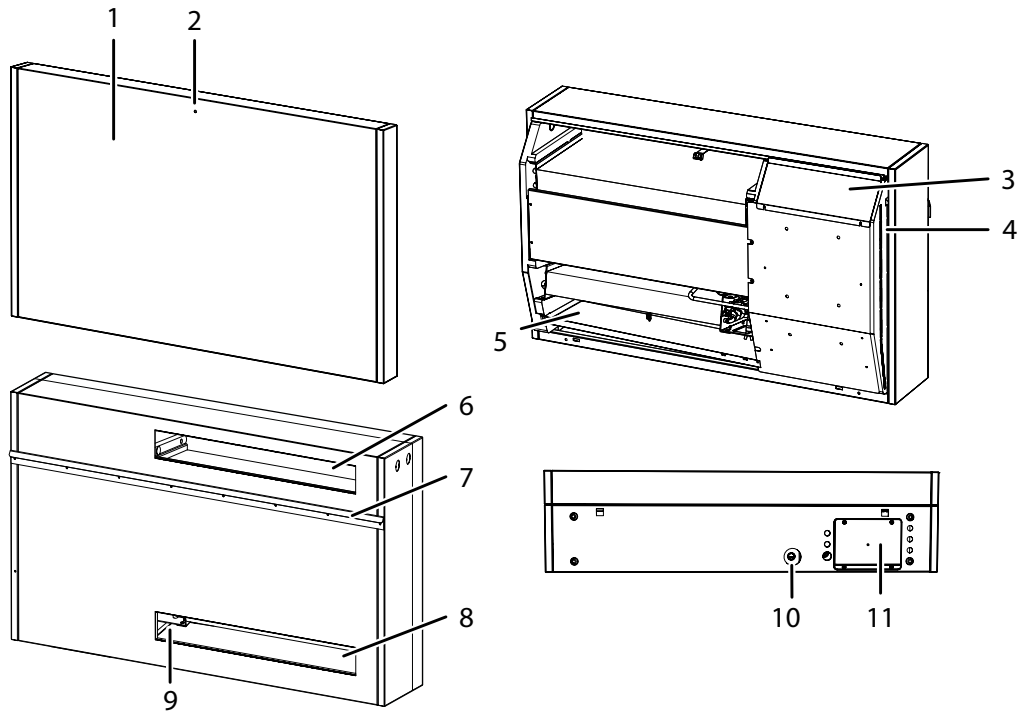

Fig 4: Components - CDP-T models

- | | |
|---------------------------------------|---------------------------------------|
| 1 Front cover | 7 Wall rail |
| 2 LED light | 8 Air inlet |
| 3 Control panel (behind the cover) | 9 Humidity sensor |
| 4 Cable groove (for accessories only) | 10 Water drain |
| 5 Drip tray | 11 Power connection (behind the flap) |
| 6 Air outlet | |

Cable groove for accessories

Two grooves make it easy to guide the cables from the control panel to the power connection and out of the unit.

Groove B is intended for use with an external RH% sensor cable, as this avoids interference. All other accessory cables are to be placed in groove A1-A2.

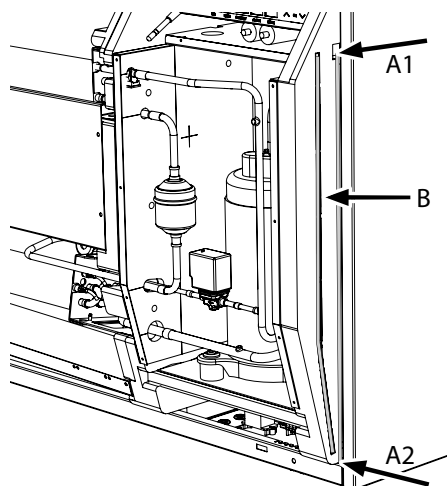

Fig. 5: Cable groove for accessories

Installation

General requirements

Water quality in indoor pools

Pay attention to the right combination of chemicals in your swimming pool in order not to endanger the health of the users and the inventory. Shown below are the threshold values which apply to indoor swimming pool products in accordance with EN/ISO 12944-2, protection class C4. Comply with these threshold values in order for the warranty to remain valid.

When adding chemicals

The following guideline values apply for the addition of chemicals in swimming pools:

Chemical	Value
Free Chlorine content	1.0 - 2.0 ppm
Combined chlorine content	max. 1/3 of free chlorine content
pH value	7.2-7.6
Total alkalinity	80–150 ppm
Calcium hardness	250–450 ppm
Total dissolved solids (TDS)	< 2000 ppm
Sulphates	< 360 ppm

Tab. 1: Guideline values for the addition of chemicals

With own chlorine production

The following guideline values apply in swimming pools with their own chlorine production:

Chemical	Value
Salt (NaCl)	< 30000 ppm
Total dissolved solids (TDS)	< 5500 ppm
pH value	7.2-7.6
Total alkalinity	80–150 ppm
Calcium hardness	250–450 ppm
Sulphates	< 360 ppm

Wall mounting

Assembly CDP 40-50-70

- ✓ There should not be a heat source near the place of installation.
 - Heavy equipment: installation and relocation of the unit require at least two people.
1. Determine a suitable place of installation and measure where the wall rail must be mounted. Pay attention to the minimum distances from the ceiling and floor.

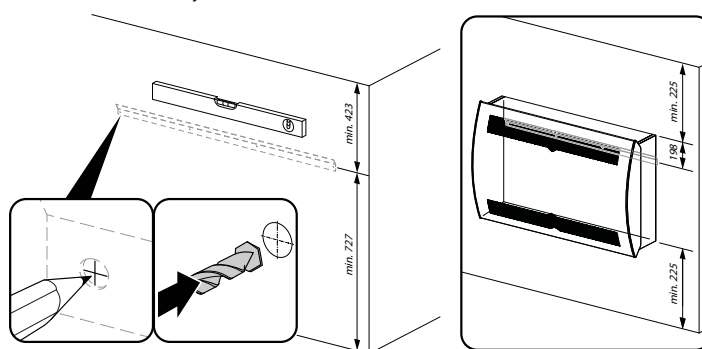

Fig. 6: Minimum mounting distances (mm)

- Fix and level the wall rail with the dimensions shown. Make sure to use suitable screws and wall plugs. **NOTICE! Fix the unit horizontally to ensure proper condensate drainage.**

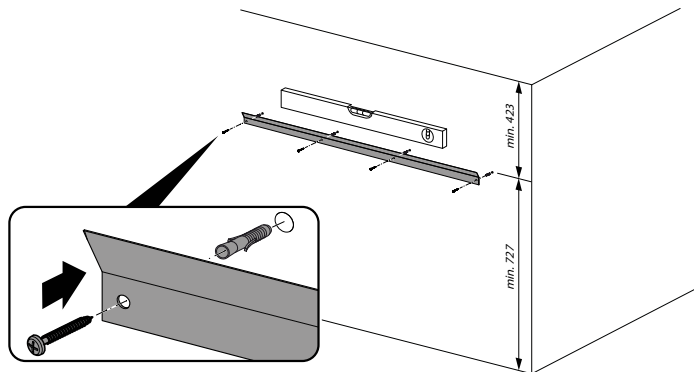

Fig. 7: Mounting the wall rail

- Mount the two spacers on the back of the unit.

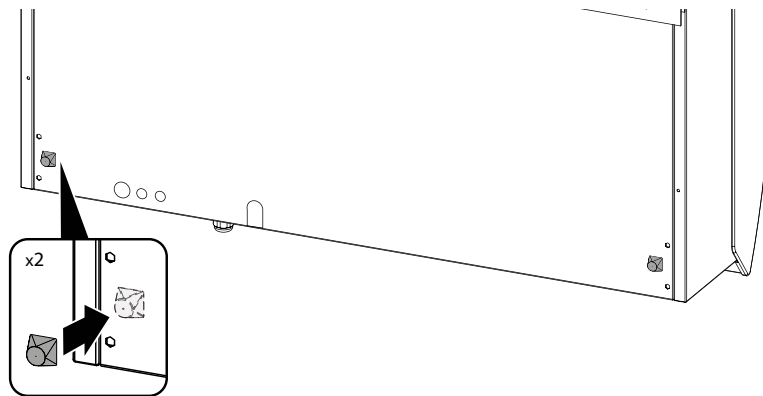

Fig. 8: Mounting the spacers

- Connect a 3/4 inch drain hose to the drain outlet on the bottom of the unit and guide the condensate drain hose through the wall. Make sure the drainage has a slope of at least 2 %.

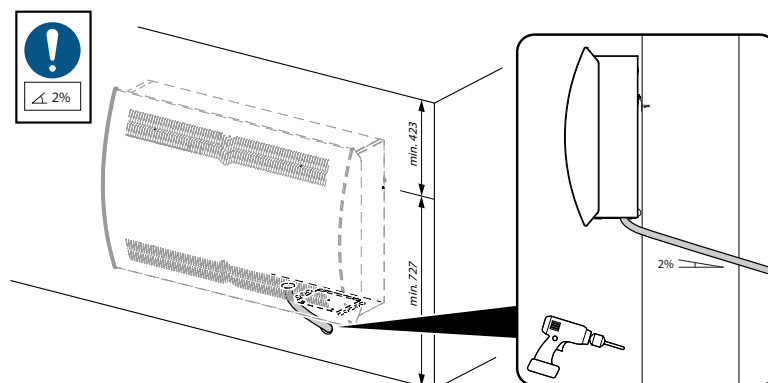

Fig. 9: Mounting the drain outlet

INFO

Alternatively, you can fit a condensate pump to the water outlet in order to pump the water to a drain.

5. Hang the unit on the wall rail.

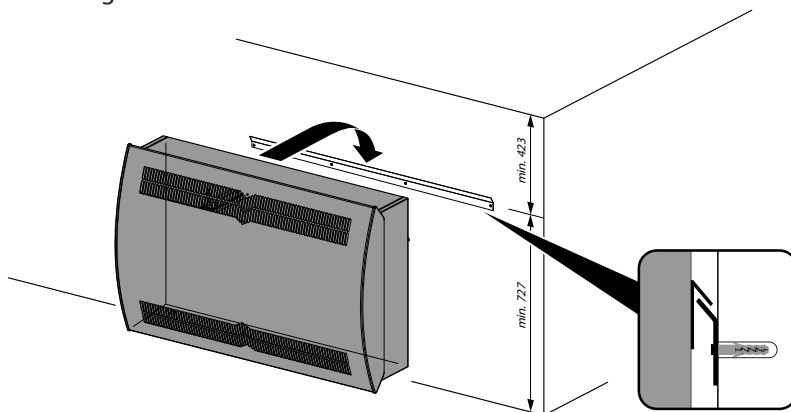

Fig. 10: Hanging up the dehumidifier

6. Use a spirit level to ensure that the unit is aligned horizontally.

**Assembly CDP-T
40-50-70**

- ✓ There is no heat source near the place of installation.
- 1. Determine a suitable place of installation and measure where the wall rail must be mounted. Pay attention to the minimum distances from the ceiling and floor.

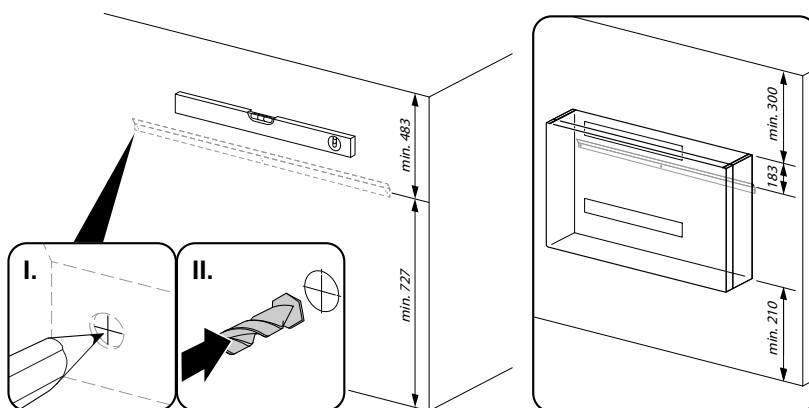

Fig. 11: Minimum mounting distances (mm)

- 2. Fix and level the wall rail with the dimensions shown. Make sure to use suitable screws and wall plugs. NOTICE! Fix the unit horizontally to ensure proper condensate drainage.

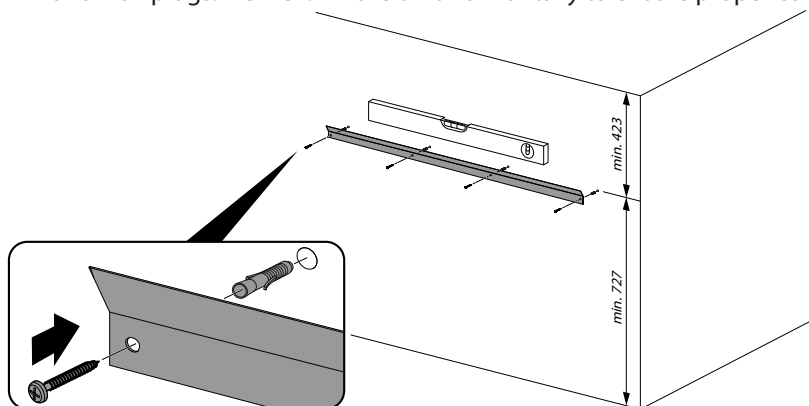

Fig. 12: Mounting the wall rail

3. Prepare the wall openings for supply air and extract air according to the dimensions in the following illustration.

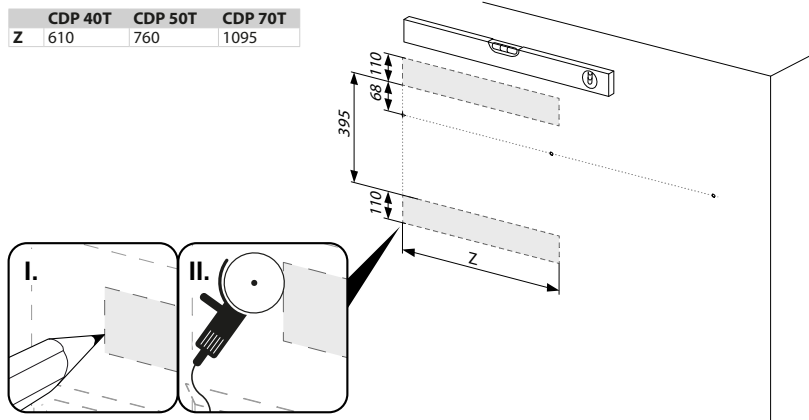

Fig. 13: Preparing wall openings

4. Mount the CDP-T wall ducts in the wall openings. **NOTICE!** For correct installation, please read the instructions for the CDP-T wall duct.

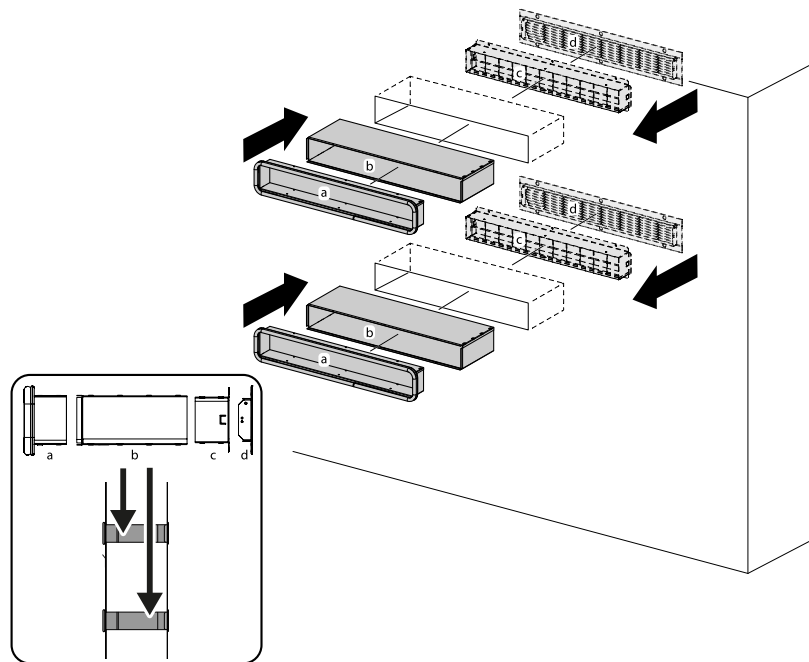

Fig. 14: Mounting the wall ducts

5. Mount the two spacers on the back of the unit.

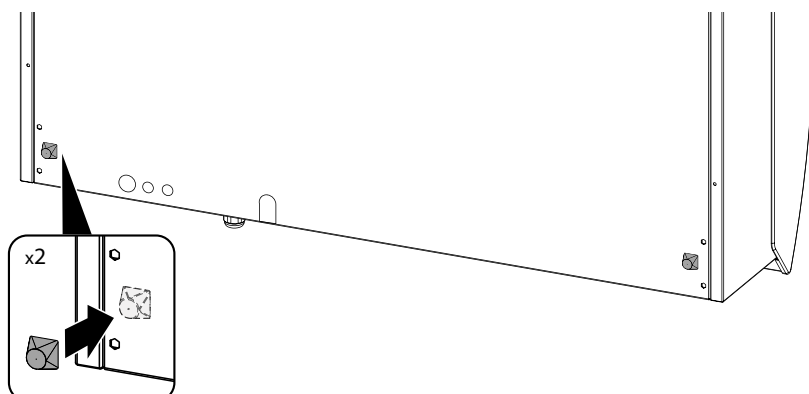

Fig. 15: Mounting the spacers

6. Hang the unit on the wall rail.

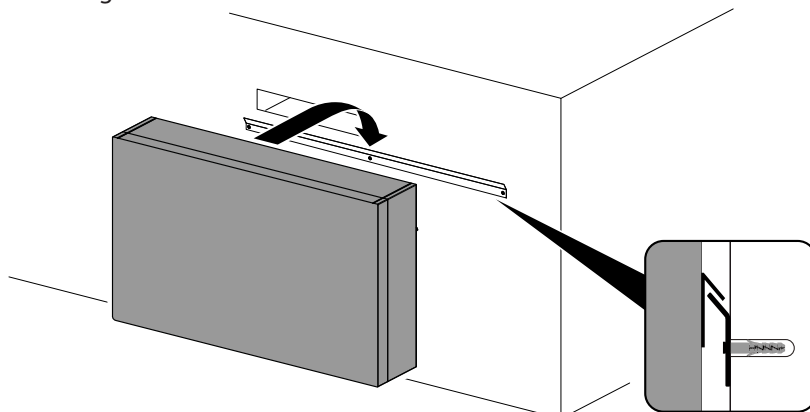

Fig. 16: Hanging up the dehumidifier

7. Use a spirit level to ensure that the unit is aligned horizontally.

Power connection



! DANGER

Risk of electric shock!

You can be severely injured by an electric shock.

- Make sure that the cable to be connected does not carry any current.



NOTICE

Risk of damaging the unit if it has been laid down.

The compressor can be damaged permanently if the unit is started up just after it has been lying down.

- If the unit has been laid down (for example for transport or assembly), wait 1 hour before starting up the unit.

Power supply connection

- ✓ Doors and windows must be closed.
- ✓ The air inlet and air outlet openings must be free from obstructions.
- 1. Loosen the two screws that secure the lid to the power connection.
- 2. Tilt the lid down.
- ⇒ You can now access the power terminals.

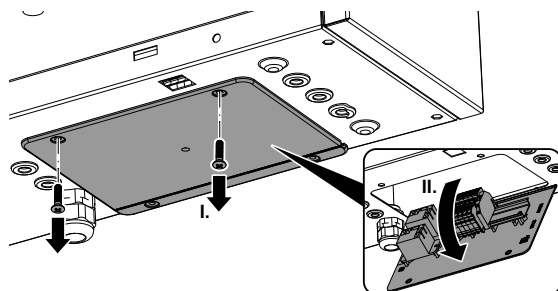

Fig. 17: Opening the power connection lid

3. Guide the cable for the mains connection through the PG cable gland and connect the unit to the mains according to the description on the nameplate.

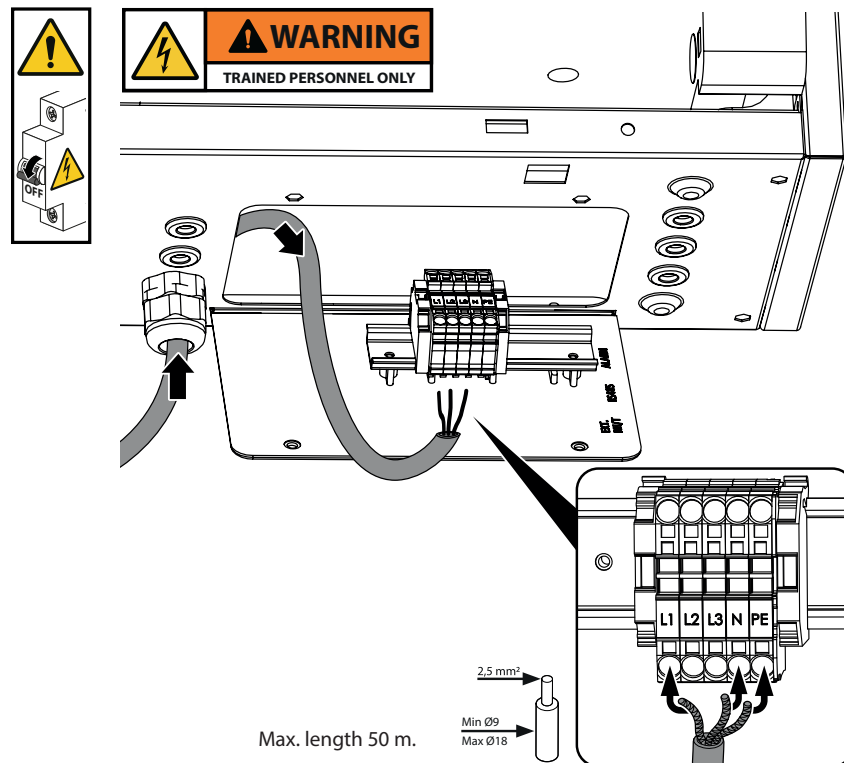

Fig. 18: Guiding the cable through the PG cable gland

INFO

See also the circuit diagram in the annex.

4. Close the lid and fix it with the screws again.

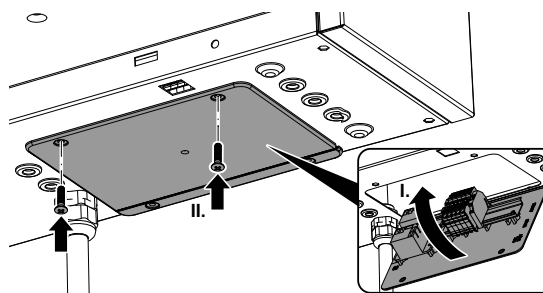

Fig. 19: Closing the power connection lid

INFO

The power cable must be certified and installed in a manner that allows the equipment to be easily and quickly disconnected in the event of an emergency.

Control panel interfaces

The interfaces and connections on the control panel enable communication with the dehumidifier. Likewise, accessories such as an RH/T sensor, an alarm or a heating coil can be connected.

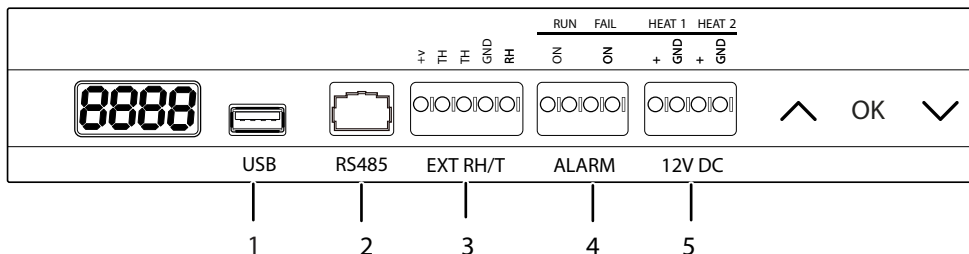

Fig. 20: Control panel interfaces

Item	Interface	Description
1	USB	USB is used for data logging and software updating. See chapters Updating the software and Log files.
2	Modbus RTU (RS-485)	Modbus connection. A modbus parameter list is available, if required.
3	External RH/T sensor	Terminals for connecting an external humidity/temperature sensor. For installation, see the wiring example on page 15.
4	Alarm	An external alarm can reveal whether the unit is operating normally or has an error. For installation, see the wiring example on page 15.
5	12 V DC heat control	Connection of a low-pressure hot water generator or an electric heater helps to control the indoor temperature. Please contact your dealer for more information.

Tab. 2: Control panel interfaces

Connection of an external RH/T sensor (optional)

You can optionally connect an external RH/T sensor to the unit that overrides the internal sensor. The external sensor can, for example, be connected as follows:

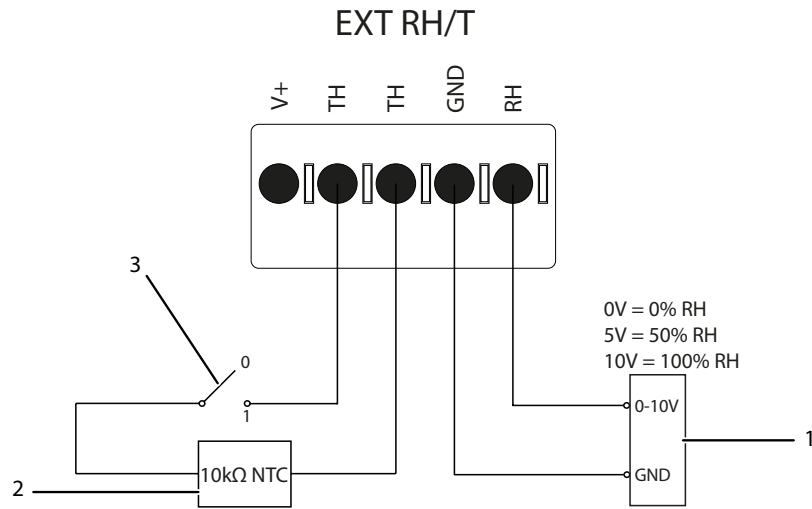

Fig. 21: Connecting an external RH/T sensor

- 1. External humidity sensor or control unit
- 2. External temperature sensor or resistor
- 3. ON/OFF switch for external sensors

INFO

The operating range is between 40 % and 99 % RH. Outside this range, the dehumidifier is in standby mode.

RUN/ FAIL connection for alarm

You can optionally connect an external alarm to the unit to determine whether the unit is operating normally or has an error.

Connect an external circuit to the RUN/FAIL connection of the main PCB to use this option. Below is an example of how to use the RUN/FAIL circuit:

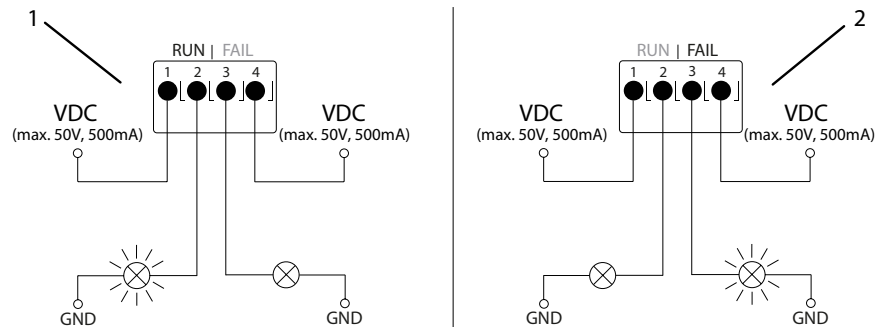

Fig. 15: RUN/FAIL connection

- 1. Operating mode
- 2. Fail mode

INFO

See also the illustration of the main PCB in the chapter Annex.

Operation

Control panel



DANGER

Risk of electric shock!

You can be severely injured by an electric shock.

- Make sure that the cable to be connected does not carry any current.

Accessing the control panel

- ✓ The power supply to the unit must be disconnected.
- 1. Loosen the two screws at the bottom of the unit.
- ⇒ The front cover can now be removed.
- 2. Pull the front cover upwards and remove it.

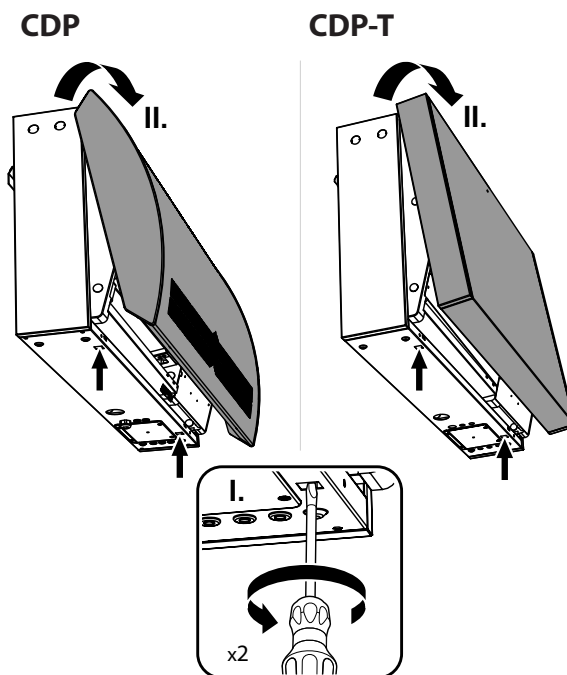

Fig. 23: Removing the front cover

- 3. Loosen the two screws of the control panel cover and remove the cover.

Menu overview
Software v.1.50
and newer



The 4-digit menu display is divided into two sections. The first two digits show the code and the last two digits show the value of the code.

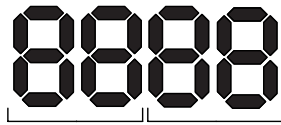

Fig. 24: Display

By default, the display will show the relative humidity (RH %). The value is measured by the internal humidity sensor or by an external humidity/temperature sensor, if connected.



Fig. 25: Standard display view

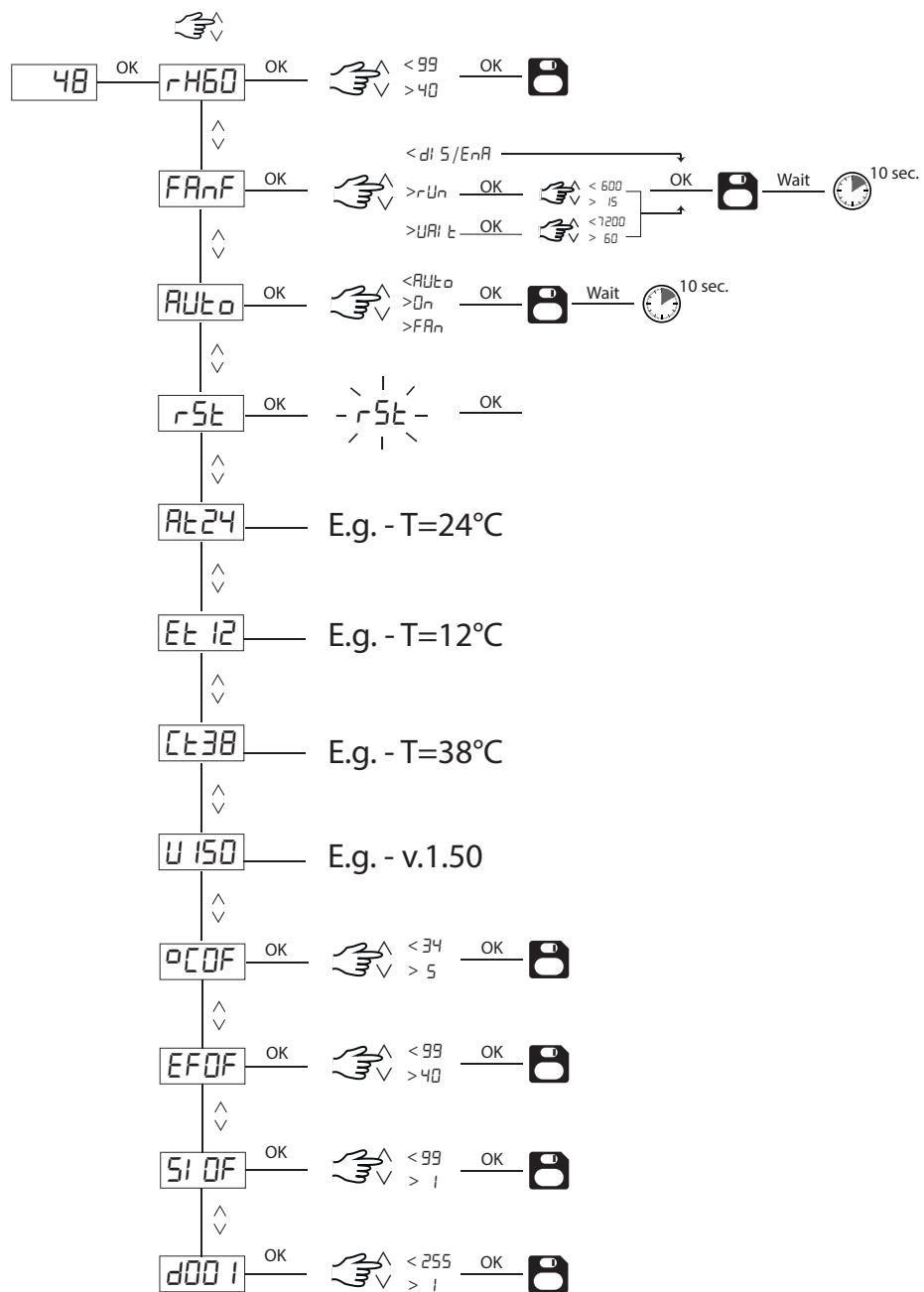

Fig. 26: Menu overview

INFO

If the menu is displayed differently, you are using an older software version. If necessary, update the software (see chapter Updating the software).

Menu buttons



Press and hold the OK button for 3 seconds to enter the menu.



Open menu page / Adjust value.



NOTICE

If no button is pressed for 10 seconds, the standard view is shown again.

Menu description

Code	Function	De- fault value	Value range	Description
rH	Relative humidity (RH)	60	40-99	The unit will start dehumidifying as soon as the sensor measures a relative humidity higher than the set value. Please note the hysteresis of +/- 2 %.
FanF	Fan function			
diS	Disable/enable	diS	Dis/ enA	The fan will run periodically when idle to take air samples. diS enables or disables this function.
Run	Run time	60	15-600	Fan run time in seconds.
wait	Wait time	3600	60- 7200	Fan wait time in seconds.
AUTO	Mode selection	AUTO		
			AUTO	Automatic operationX of fan and compressor based on the RH setpoint.
			On	Fan and compressor always active when power is connected (manual mode).
			Fan	Fan always active. Automatic operation of the compressor based on the RH setpoint.
rST	Reset		rST	Soft reset of the unit. Corresponds to switching power supply off and on. If rST flashes in the display, press the OK button to reset.
At##	Temperature			Ambient temperature values measured by the RH sensor. Not adjustable.
Et##	Temperature			Current value measured by the evaporator temperature sensor. Not adjustable.
Ct##	Temperature			Current value measured by the condenser temperature sensor. Not adjustable.
U150	Software version			Current unit software version. Not adjustable.

Code	Function	De- fault value	Value range	Description
SI	Service interval (weeks)	ON (OFF)	1-99	When the service interval function is enabled, the unit will display 5E- when maintenance is due.
d001	Modbus slave ID	001	1-255	Connection via Modbus is possible. The default Modbus slave ID of the unit is 1. It can be changed to a value between 1 and 255.
°C	°Celsius (with accessory only)	ON (OFF)	5-34	The electric / hot water heating coil (accessory) starts heating when the temperature is below the set value. Please note the hysteresis of +/- 2 °C.
EF	Extract air fan (with accessory only)	ON (OFF)	40-99	The extract air fan (accessory) switches on independently of the dehumidifier as soon as the humidity is above the set value. The value is measured in % RH. Please note the hysteresis of +/- 2 %.

Maintenance and troubleshooting

Preventive maintenance activities

To ensure that the unit always meets the technical requirements, preventive maintenance activities have to be carried out at specified intervals. This can prevent breakdowns and inefficient operation and maximise the service life of the unit.

The fan motor(s) and compressor have permanent lubrication and require no particular maintenance.

The factory warranty is only valid if preventive maintenance activities have been carried out and documented. This documentation can be in the form of a written maintenance protocol.



DANGER

Risk of electric shock!

You can be severely injured by an electric shock.

- Make sure that the cable to be connected does not carry any current.



CAUTION

Sharp edges!

The cabinet of the unit may have sharp edges on which you can cut yourself.

- Wear protective gloves when opening the unit.



CAUTION

Very hot and very cold parts inside!

There may be very hot or very cold parts inside the units on which you can easily burn yourself.

- Switch off the unit half an hour before opening it.
- Wear protective gloves when working inside the unit.



Scope of maintenance

The following parts require preventive maintenance:

Maintenance interval	Task	To be carried out by:
Monthly	Clean air inlet filter	Operating personnel
	Clean condensate tray	Operating personnel
	Clean condensate outlet	Operating personnel
Annually	Inspect dehumidifier	Qualified personnel

Cleaning the interior (monthly)

- ✓ The power supply to the unit must be disconnected.
- 1. Loosen the two screws on the bottom side of the unit.
- ⇒ The front cover can be removed.

2. Pull the front cover upwards and remove it.

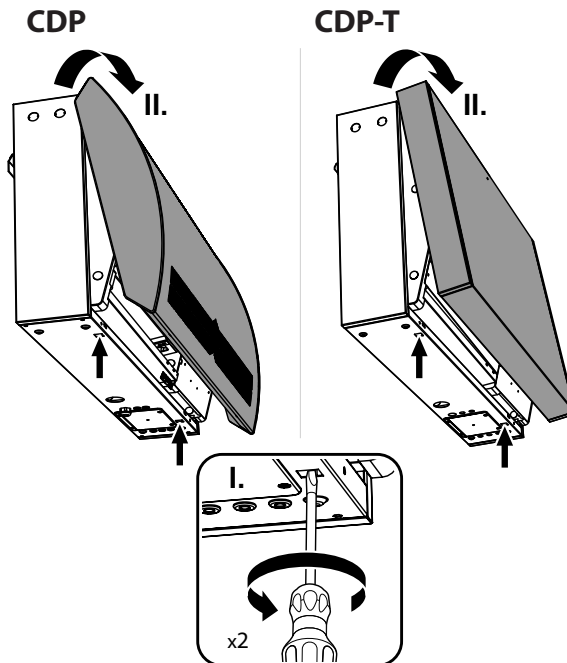

Inspecting the dehumidifier (annually)

- ⇒ The filter is located on the inside of the front cover.
3. Take the filter out of the filter holder.
4. Clean the filter thoroughly with a vacuum cleaner.
5. If necessary, clean the filter with soapy water.
6. Put the filter back into the filter holder.
7. Clean the condensate tray and the condensate outlet with lukewarm soapy water.
8. Fit the front cover to the dehumidifier and close the unit using the two screws.

NOTICE

If the filter is faulty, replace it. Please contact your dealer if you wish to purchase a new filter.

- ✓ The power supply to the unit must be disconnected.
- 1. Open the dehumidifier as described on page 18.
- 2. Inspect the inside of the dehumidifier.
- 3. Use a vacuum cleaner to remove dust and dirt from the unit.
 - ⇒ Pay particular attention to thorough cleaning of the condenser with a soft brush along the fins.
- 4. If necessary, clean the evaporator fins with lukewarm soapy water.

Service Personnel Qualifications

The following operations may only be carried out by service personnel with appropriate qualifications, as defined in Annex HH of EN/IEC 60335-2-40 and applicable national regulations:

- Breaking into the refrigerant circuit
- Opening sealed components
- Opening ventilated enclosures

Service personnel must be trained and certified for the safe handling of flammable refrigerants. They shall possess the competence to:

- Understand and apply national regulations and safety standards for refrigeration systems
- Use appropriate tools, protective equipment, and leak detection methods
- Perform installation, maintenance, and repair tasks without creating hazards for themselves or others

Only qualified service personnel are permitted to perform these tasks.

- Checks to the area** Before commencing work on systems containing flammable refrigerants, safety checks shall be carried out to ensure that the risk of ignition is minimised. Prior to undertaking any repair work on the refrigeration system, the following requirements shall be met.
- Work shall be carried out under a controlled procedure to minimise the risk of flammable gas or vapour being present.
 - All maintenance personnel and any other persons in the area shall be informed of the nature of the work being undertaken. Work in confined spaces shall be avoided wherever possible.
 - Ensure that the area is in the open or that it is adequately ventilated before breaking into the system or conducting any hot work.
 - The area shall be checked using an appropriate refrigerant detector before work begins and continuously during the work. Leak detection equipment shall be suitable for use with the applicable refrigerant and shall be non-sparking, adequately sealed, and intrinsically safe.
 - Where hot work is required on the system, suitable fire-fighting equipment shall be readily available. This shall include dry powder or CO₂ fire extinguishers.
 - No person carrying out work on a refrigeration system shall use any source of ignition that could create a risk of fire or explosion. This includes smoking. A "NO SMOKING" sign shall be clearly displayed during service activities.

Updating the software

Updating the software

Update the software of the unit in the following way:

- ✓ Have an empty USB stick ready (max. 16 GB).
- 1. Obtain the latest software version from Dantherm and copy the file to your empty USB stick.
- 2. Insert the USB stick into the USB port of the control panel.
 - ⇒ The unit will detect the new software and install it automatically. The installation process takes approx. 30 seconds. The following is displayed during installation: "Erasing - Flashing - Done - Log".
 - ⇒ A log file is stored on the USB stick.
 - ⇒ As soon as the display shows the standard view again, the USB stick can be removed.

INFO

If the display only shows "Log" and the standard view appears again after a few seconds although the USB stick is inserted, the software update has failed. In this case, format the USB stick to FAT32 and repeat the software update.

Formatting to FAT32

If the unit does not update to the latest software version, format the USB stick to FAT32 format as follows.

- ✓ There is no data on the USB stick.
- ✓ The USB stick has a maximum memory size of 16 GB.
- 1. Insert the USB stick into the USB port of the computer.
- 2. Press the Windows key (⊞) + r.
- 3. Type "CMD" and press the enter key.
- 4. Type the following: format/FAT32 X
"X" is the letter of the USB drive.
- 5. Press the enter key.
 - ⇒ The following message is displayed: "Insert new disc for drive X: and press ENTER when ready".
- 6. Press the enter key.
 - ⇒ The USB stick is being formatted.
- 7. As soon as the USB stick is formatted 100 %, press the enter key.
 - ⇒ Formatting is completed.

Log files

Data log access

You have the option to read the log file of the unit without updating the software. To do so, please proceed as follows:

1. Insert an empty USB stick formatted with FAT32 with a maximum storage capacity of 16 GB into the USB port of the control panel.
 - ⇒ All collected data records are saved in the data_log CSV file. The data records will not be deleted from the PCB and can thus be stored on several USB sticks.
 - ⇒ If the display shows the “Log” message and then returns to the standard view, the log data has been stored successfully.
2. Remove the USB stick.

INFO

Data logging requires 2 kB of the backup SRAM (with battery) for data records.

The interval for data logging is three hours. A status change to fail mode also requires data memory.

If the entire memory is occupied, the new data will replace the oldest.

Data log content

Excel column	Output text	Description
Timestamp	<dd:mm:hh:ss>	Log time since the last compressor start sequence
T_amb	<-40...100>	Ambient temperature (-40 = not conn.)
T_amb_int	<-40...100>	Temperature of internal RH/T sensor (-40 = not conn.)
T_amb_ext	<-40...100>	Temperature of external RH/T sensor (-40 = not conn.)
T_aux	<-40...100>	Auxiliary temperature (input) (-40 = not conn.)
T_cond	<-40...100>	Condenser temperature (-40 = not conn.)
T_evap1	<-40...100>	Temperature of evaporator 1 (-40 = not conn.)
T_evap2	<-40...100>	Temperature of evaporator 2 (-40 = not conn.)
T_set	<5...34>	Setpoint of desired temperature (default: OFF)
RH_amb	<0...100>	Ambient humidity (0 = not conn.)
RH_amb_int	<0...100>	Humidity of internal RH/T sensor (0 = not conn.)
RH_amb_ext	<0...100>	Humidity of external RH/T sensor (0 = not conn.)
RH_set	<40...99>	Humidity setpoint (default: 60)
ExtFanSet	<40...99>	Setpoint of extract air fan (default: OFF)
Service	[blank]	Service interval disabled
	ENABLED	Service interval enabled
Mode	SB	Stand-by mode state
	STARTUP	Start-up mode state
	DEH	Dehumidifying state
	ICE	Defrosting state
	LP	Low-pressure fail mode state
	HP	High-pressure fail mode state
	SENS	Sensor fail mode state
	ABMT	Ambient temperature fail mode
	AMBRH	Ambient humidity fail mode

Excel column	Output text	Description
Error	EVAP	Evaporator sensor error
	COND	Condenser sensor error
	AUX	Auxiliary sensor error
	AMB_INT	Internal outside air sensor error
	AMB_EXT	External sensor error (always shown when not conn.)
Reason for logging	IDLE	Automatically made every 3 hours
	ERROR	An error has occurred
Sensor	SHT31	New sensor type
	ChipCap2	Old sensor type

Tab. 3: Data log content

Troubleshooting

The unit can display certain information and error messages that can be used to locate the fault. There is an LED light at the front of the unit indicating which mode the unit is in and whether there is a fault.

All messages and the associated problems are explained in the sections below.

NOTICE

Switch off the unit if it does not function properly and the reason for the defect cannot be determined in order to avoid damage.

Contact a service technician.

Information messages

Display	Description	Explanation
<i>Rbrh</i>	The relative humidity is outside the measurable range	The display will automatically show the standard view as soon as the relative humidity is within the measurable range again.
<i>Rbt</i>	The ambient temperature is outside the measurable range	The display will automatically show the standard view as soon as the ambient temperature is within the measurable range again.
<i>LDSS</i>	The connection to the radio remote control is interrupted	As soon as the connection is re-established, the error message can be acknowledged by pressing OK.
<i>SEr</i>	Maintenance is due	As soon as a new service interval is set, the display will return to standard view.
<i>PRIr</i>	The unit tries to connect to a radio remote control	The display will automatically return to standard view after a few seconds.
<i>LPEo</i>	Preliminary low pressure warning	The unit will restart and return to standard view if the error is corrected after the restart. If the error persists, the display will show an LP error. See Troubleshooting guide.

Tab. 4: Information messages

Error messages

If one of the faults described here occurs, the unit stops automatically and can no longer be started. Press OK after the error has been corrected to start unlocking.

Display	Description	Action required
5E _n 5	Sensor error	Press the up or down button to determine which sensor is faulty.
CO _{nd}	Condenser sensor	
EU _{AP}	Evaporator sensor	
r _h o _t	Humidity sensor	
LP	Low pressure detection	The error must be detected and corrected. See Troubleshooting guide.
HP	High pressure detection	The error must be detected and corrected. See Troubleshooting guide.

Tab. 5: Error messages

INFO

If no button is pressed for 10 seconds in the event of a sensor error, 5E_n5 is displayed again.

Unlocking

Loc

This message indicates that the unit is locked. If no button is pressed within 5 seconds, the error state view is displayed again.

Please proceed as follows to unlock the unit:

1. Press the ✓ button.
 - Unlock function UnL_o is displayed.
2. Press OK.
 - Test function tE₅t is displayed.
3. Press OK.
 - A test is carried out to check whether the error has been corrected.
 - cccc indicates that the error has been corrected and the device has been unlocked successfully.
 - FRI L indicates that the error has NOT been corrected and the device is still locked.



LED overview and troubleshooting v. 1.50

LED colour	LED behaviour	Audible alarm	Cause	Action required
OFF	-	-	No power supply to PCB	-
Blue	Flashing once	Beep for 1 second	Unit starts up	-
	Slow flashing	-	Self check is carried out. The LED will flash until the self-test is completed.	-
Green/Yellow	Flashing	-	Unit is in remote pairing mode	-
Green	Continuous light	-	Unit is in normal operation	-
Yellow	Continuous light	-	Service interval expired	Perform maintenance and set new interval.
Red	Flashing 2x	Beep for 3 seconds	LP alarm	See Troubleshooting guide.
	Flashing 4x		HP alarm	See Troubleshooting guide.
	Flashing 6x		Sensor alarm	See Troubleshooting guide.

Tab. 6: LED overview v. 1.50

Troubleshooting guide

Display text		Type	Fault	Possible cause	Unit behaviour	Troubleshooting	Solution
[None]	-	-	-	Power supply disconnected Fuse "F1" on main PCB blown	LED + display off	Check 230 V supply Check PCB fuse	Re-establish power supply Replace fuse
Abt.	Info	No fault	Ambient temperature is out of operating range Ambient humidity is out of operating range	Unit in standby	-	-	-
Abrh							
LPCo	Alarm	LP condition	Refrigeration circuit leak causing loss of refrigerant	LPCo will persist until LP fault is triggered after 3 separate attempts to clear the fault condition. -> Condition is similar to expansion valve failure.	Confirm compressor is running Confirm fan is running Confirm defrost valve is closed (no leak) -> No temperature difference between the coils	Repair refrigeration circuit	
			Compressor defective	LPCo will persist until the fault is triggered after 3 separate attempts to clear the fault condition. No or irregular noise from the compressor housing.	Compressor does not start at all: Confirm there is voltage at the compressor terminals. Compressor tries to start but will not run (clicking/humming from compressor): Confirm that compressor voltage is 230 V +/- 10 % Confirm that the run capacitor is within the specifications	Replace compressor Replace compressor Replace run capacitor	
			Thermostatic expansion valve (TEV) defective	LPCo will persist until LP fault is triggered after 3 separate attempts to clear the fault condition. Evaporator coil can build up a small amount of ice around the TEV. -> Condition can be similar to leak in refrigeration circuit.	Verify if TEV is visually damaged: Check TEV head / capillary tube / TEV sensor bulb for cracks and corrosion	Replace TEV	

Display text	Type	Fault	Possible cause	Unit behaviour	Troubleshooting	Solution
			<p>Defective temperature sensor for evaporator coil or condenser outlet tube</p> <p>Poor contact to evaporator coil or condenser outlet tube</p> <p>Poor connection in plug on PCB</p> <p>PCB failure</p> <p>Sensor wire defective</p>	<p>Unit seemingly functions normally with no apparent fault. Evaporator coil cold, condenser coil warm.</p> <p>Permanent or temporary LP failure.</p>	<p>Confirm sensor resistance</p> <p>Check connection to PCB for corrosion</p> <p>Check sensor wire for integrity</p> <p>→ Sensor resistance and connection OK --> defective PCB</p>	<p>Replace sensor</p> <p>Clean connection to PCB</p> <p>Perform PCB reset procedure</p> <p>Replace PCB</p>
			<p>Special operation conditions:</p> <p>Low ambient temperature and humidity levels can cause insufficient temperature difference between condenser and evaporator coil, which will trigger LPCo fault.</p>	<p>No water leaks from the dehumidifier.</p> <p>LPCo fault will be periodically present</p> <p>LP fault can be triggered.</p> <p>Self check will reset fault condition.</p>	<p>Confirm that the condenser is running</p> <p>Confirm fan is running</p> <p>Confirm magnetic defrost valve is closed (no leak).</p>	<p>Perform self check</p> <p>Wait for room temperature to increase</p>
			<p>Defrost valve leak</p> <p>PCB failure causing incorrect operation of defrost valve</p>	<p>No water leaks from the dehumidifier.</p> <p>LPCo fault will be periodically present</p> <p>LP fault can be triggered.</p>	<p>Hissing from defrost valve</p> <p>Voltage at defrost valve coil when there is no ice on evaporator coil</p>	<p>Actuate the valve by means of external solenoid or 230 V AC to valve coil</p> <p>Replace defrost valve</p> <p>Perform PCB reset</p> <p>Replace PCB</p>
LP	Alarm	LP fault	<p>LPCo fault has been triggered too many times consecutively</p>	<p>LP fault is triggered</p>	<p>See LPCo fault finding procedures</p>	-
HP	Alarm	HP fault	<p>Fan fails periodically</p>	<p>HP fault is triggered.</p> <p>Unit seemingly operating normally.</p> <p>Self check will reset fault condition.</p>	<p>Confirm that the fan is working.</p> <p>If the fan switches off for no apparent reason, this is probably caused by the thermal protection circuit of the internal fan motor. It disables the motor if the winding temperature is too high.</p>	<p>Replace fan</p>
			<p>Fan failure</p>	<p>HP fault is triggered.</p> <p>Self check will not reset fault condition.</p>	<p>Confirm that the fan is working.</p>	<p>Replace fan</p>

Display text	Type	Fault	Possible cause	Unit behaviour	Troubleshooting	Solution
			HP temperature sensor fault	HP fault is triggered. Self check will not reset fault condition.	Measure the resistance of the temperature sensor between the "cond" and "gnd" terminals in the "temp" section of the PCB. The resistance should be in the range of 190 kOhm to 0.14 kOhm, which corresponds to -50 to 98 °C. If the resistance is not within this range, the sensor is defective or the sensor cable is broken/short-circuited.	Replace temperature sensor
			Condenser coil clogged		Inspect condenser coil fins for dust/debris.	Clean condenser coil
SENS	Alarm	Sensor failure	Sensor malfunction	Display shows SENS error followed by EVAP or COND when arrow keys are pressed, indicating a condenser or an evaporator sensor error.	Measure the resistance of the temperature sensor between the terminals of the respective sensor in the "temp" section of the PCB. The resistance should be in the range of 190 kOhm to 0.14 kOhm, which corresponds to -50 to 98 °C. If the resistance is not within this range, the sensor is defective or the sensor cable is broken/short-circuited.	Replace temperature sensor
				Display shows SENS error followed by Rh°t when the arrow keys are pressed to indicate the error of the combined temp./RH sensor.	Confirm if the sensor and/or cable is visibly damaged.	Replace sensor
LOSS	Info	-	Loss of communication to paired remote control panel	-	Check whether remote control panel is switched on. Check batteries in remote control panel.	Move display closer. Change batteries in remote control panel.

Annex Technical data

Specification	Unit	CDP 40	CDP-T 40	CDP 50	CDP-T 50	CDP 70	CDP-T 70
Operating range, humidity	%RH	40-95					
Operating range, temperature	°C	10-36					
Mounting/storage conditions, temperature	°C	3-50					
Air volume at max external pressure	m ³ /h	410		680		840	
Capacity at 30 °C - RH 60	l/day	36.2		53.2		73.9	
Specific energy consumption 30 °C - RH 60	kWh/l	0.44		0.47		0.45	
Power supply	V/Hz	1N~230+PE / 50					
Max. power consumption	kW	0.9		1.4		1.7	
Max. Ampere	A	3.8		5.8		7.7	
Refrigerant	-	R454C					
Charge	kg	0.7		0.8		1.2	
Global Warming Potential (GWP)	-	148.3					
Noise level (1 m from the unit)	dB(A)	46	43	47	44	50	47
Dimensions (length x width x height)	mm	1010 x 326 x 769	998 x 294 x 700	1160 x 326 x 769	1148 x 294 x 700	1495 x 326 x 769	1483 x 294 x 700
Weight	kg	58	59	66	67	78	80
Filter type		PPI 15					
Protection class		IPX4					

Circuit diagrams

Cooling circuit

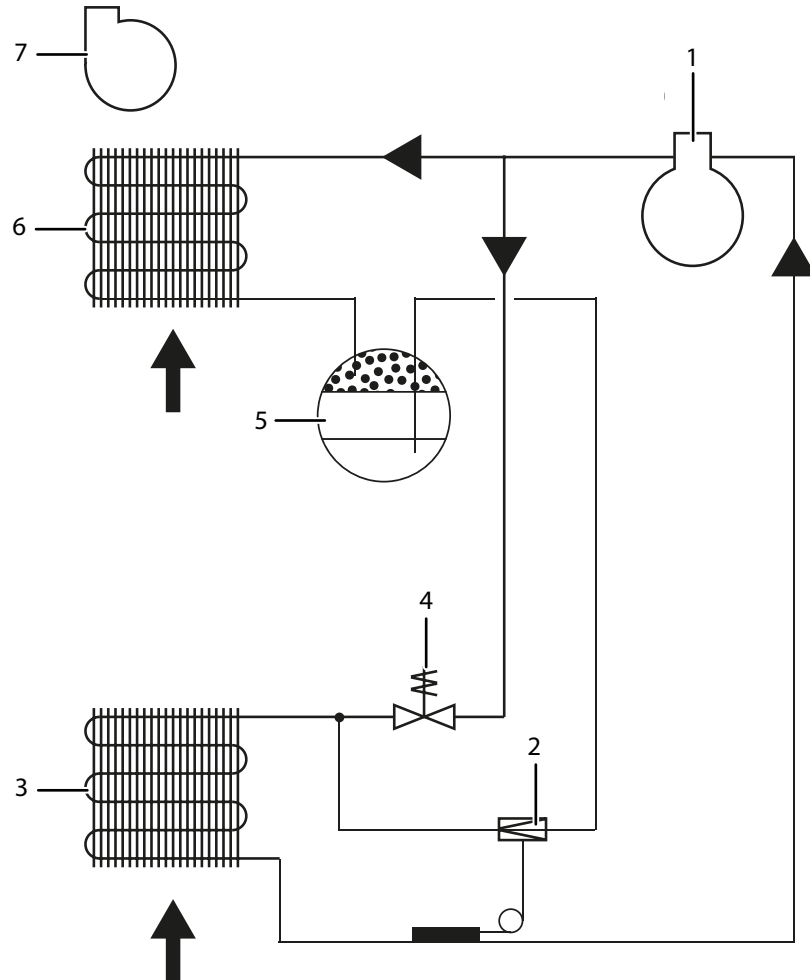

Fig. 21: Cooling circuit

- | | |
|--|------------------------|
| 1 Compressor | 5 Receiver/dry filter |
| 2 Thermostatic expansion valve | 6 Air-cooled condenser |
| 3 Evaporator | 7 Fan |
| 4 Solenoid valve for pressure equalization | |

Main PCB

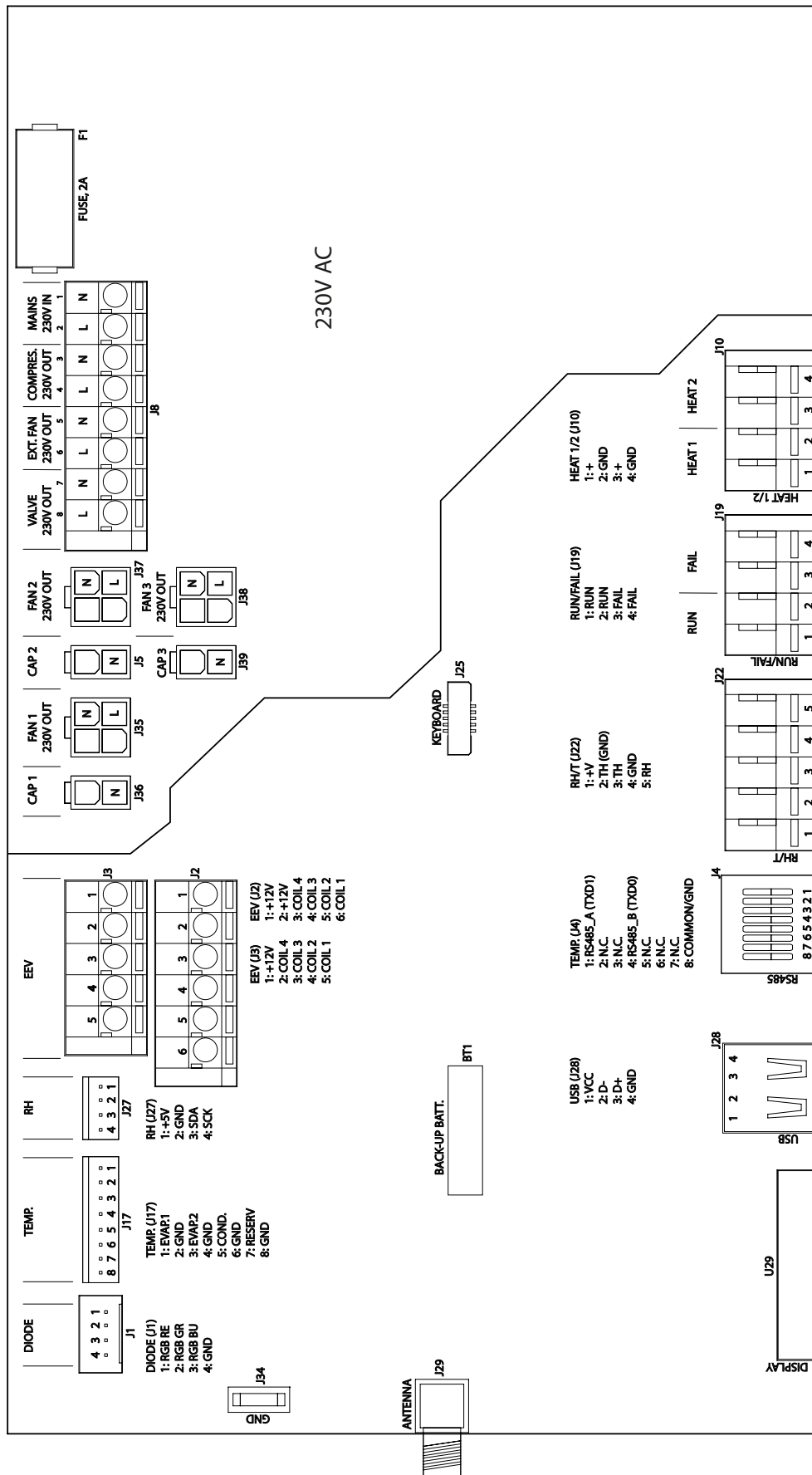

Fig. 28: Main PCB

Circuit diagram

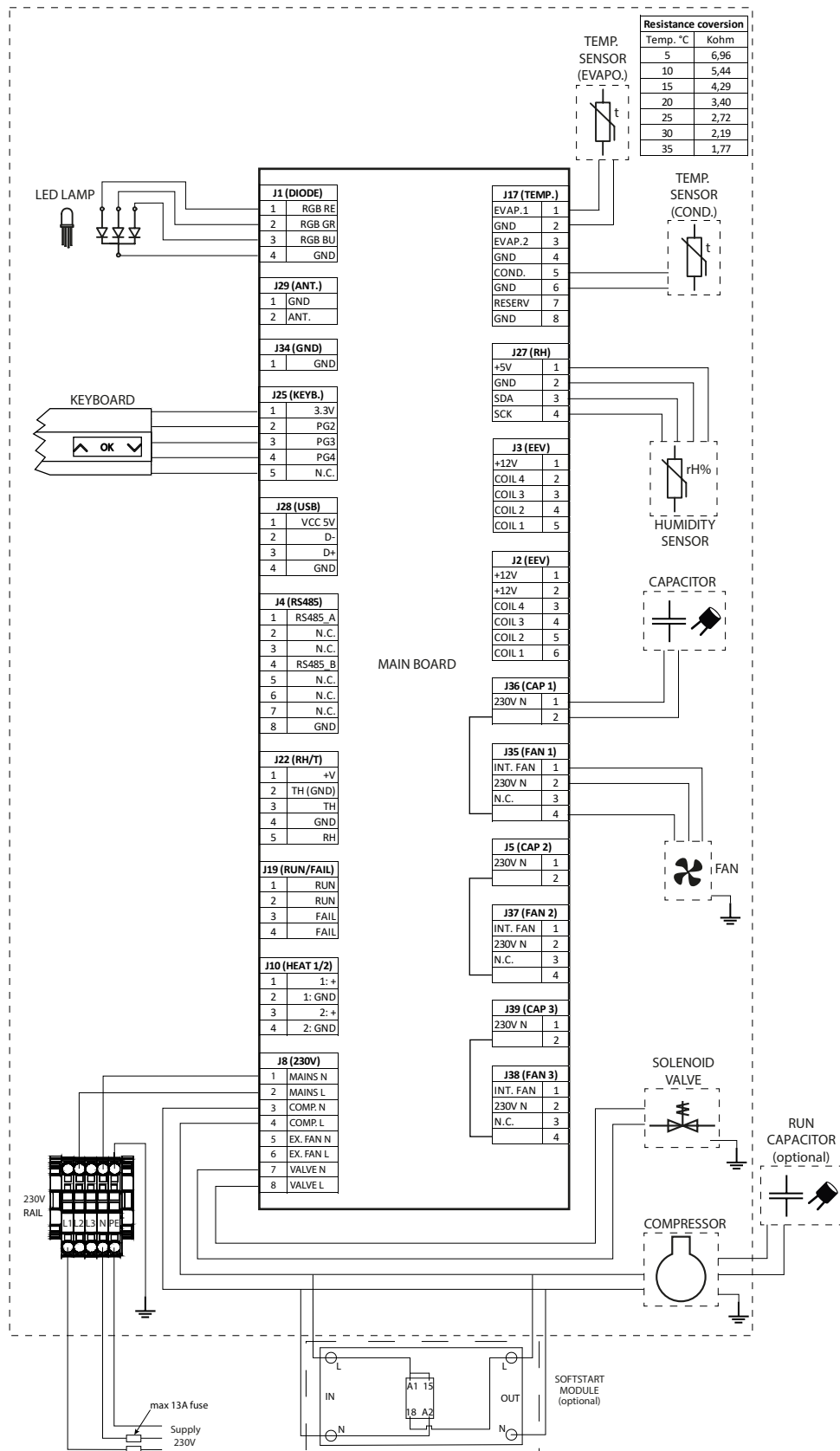

Fig. 29: Circuit diagram with softstart module

Disposal

General notes

Removal and disposal of the unit may only be performed by professionals.

All supply lines like electricity and hot water must be shut down before decommissioning and dismantling the equipment. Make sure that no water-glycol mixture is leaking.

Empty the refrigerant circuit for oil and refrigerant before dismantling.

Recycle all material according to national rules and procedures to protect the environment.

The controller contains a button cell battery. The battery must be removed before disposal. It is advisable to replace the battery after 5 years of use.



Batteries and accumulators are not to be disposed of with regular household waste. Directive 2006/66/EC OF THE EUROPEAN PARLIAMENT AND OF THE COUNCIL of 06 September 2006 on batteries and accumulators requires users to dispose the unit in a professional manner. Please dispose of batteries and accumulators in compliance with the applicable statutory provisions.



The symbol of the crossed-out waste bin on an old electrical or electronic appliance means that this appliance must not be disposed of in the household waste at the end of its service life. Collection points for old electrical or electronic appliances for free-of-charge return are provided to you locally. The addresses can be retrieved from your town or local administration. The separate collection of old electrical and electronic appliances is to enable the reuse, recycling and other forms of utilisation of old appliances and is to prevent negative impacts on the environment and human health when disposing of the hazardous substances potentially contained in the units.

Disassembly



DANGER

Risk of electric shock!

You can be severely injured by an electric shock.

- Disconnect the controller from the mains by unplugging the mains plug from the socket outlet before you open the controller!

Spare parts

How to order

Spare parts can be ordered at shop.dantherm.com

When ordering, please specify the following:

- Spare parts number/text
- Unit type
- Production number and serial number from the nameplate of the unit (or approximate date of delivery).

Reservations

Not every item will be available individually if it is part of an assembly that forms a whole or if it is part of a complete component that has been purchased. The manufacturer reserves the right to make this assessment.

The manufacturer further reserves the right to make any necessary changes to the construction and selection of components without notice, but will, as far as possible, keep the changed parts in stock.

Declaration of conformity (EU)

Dantherm Denmark A/S, Marienlystvej 65, DK - 7800 Skive hereby declares that the equipment listed below:

35152000	CDx 40
35152100	CDx 50
35152200	CDx 70

The product is in conformity with the following directives:

2014/53/EU	Radio Equipment Directive
2011/65/EU	Restriction of the use of certain hazardous substances (RoHS) Directive

and is manufactured in conformity with the following standards:

EN 60335-1:2012	Household and similar electrical appliances - Safety - Part 1 (+AC:2014 + A11:2014 + A13:2017 + A1:2019 + A2:2019 + A14:2019+A15:2021)
EN 60335-2-40:2024	Household and similar electrical appliances - Safety - Part 2-40 (+A11:2024)
EN 61000-3-2:2014	Electromagnetic compatibility (EMC) - Part 3-2
EN 61000-6-1:2007	Electromagnetic compatibility (EMC) - Part 6-1
EN 61000-6-3:2007	Electromagnetic compatibility (EMC) - Part 6-3 (+A1:2011 + A1:2011/AC:2012)
EN 50106:2008	Safety of household and similar electrical appliances - Particular rules for routine tests referring to appliances under the scope of EN 60335-1
EN 301 489-1 V1.9.2	Electromagnetic compatibility (EMC) standard for radio equipment and services; Part 1
EN 301 489-12 V3.2.1	ElectroMagnetic Compatibility (EMC) standard for radio equipment and services; Part 12
EN 300 220-2 V3.1.1	Short Range Devices (SRD) operating in the frequency range 25 MHz to 1 000 MHz; Part 2
EN IEC 63000:2018	Technical documentation for the assessment of electrical and electronic products with respect to the restriction of hazardous substances

Skive,
11.11.2025



Søren Østergaard Hansen
Managing Director



Dantherm Denmark A/S

Marienlystvej 65

7800 Skive

Denmark

Dantherm Group accepts no responsibility for possible errors and changes (en)

Der tages forbehold for trykfejl og ændringer (da)

Irrtümer und Änderungen vorbehalten (de)

Dantherm Group n'assume aucune responsabilité pour erreurs et modifications éventuelles (fr)

