

SERVICE MANUAL

AC-24

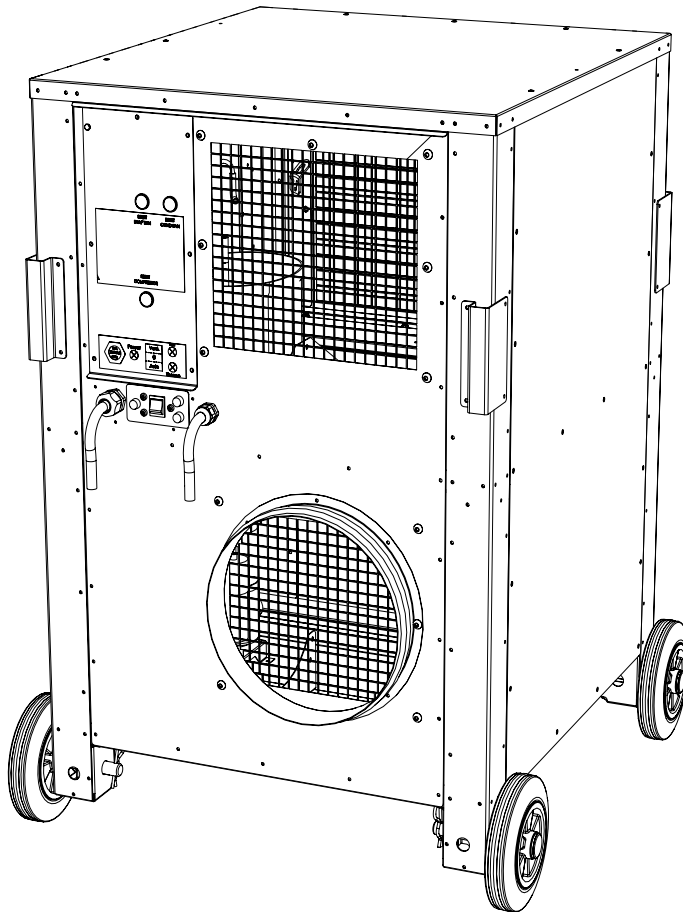



Declaration of Conformity
Dehumidification

en

Dantherm S.p.A

Marienlystvej 65
DK - 7800 Skive

Tel.: +45 96 14 37 00
Fax: +45 96 14 38 00

Declaration of following product:

Product name: AC 24

Product no.: 323043

The product is in conformity with the following directives:

2006/42/EC	Machinery Directive
2014/35/EU	Low Voltage Directive
2014/30/EU	EMC Directive
2014/68/EU	Pressure Equipment Directive
2011/65/EU	RoHS Directive
1907/2006/EC	REACH Regulation

- and is manufactured in conformity with the following harmonised standards:

DS/EN ISO 12100-1:2011	Safety of machinery - General principles for design
EN 60204-1	Safety of machinery - Electrical equipment of machines - Part 1
EN 60 335-1:2012	Household and similar electrical appliances - Safety - Part 1:
EN 60 335-2-40:2003	Household and similar electrical appliances - Safety - Part 2-40
DS/EN 61000-6-2:2005	Electromagnetic compatibility (EMC) - Part 6
DS/EN 61000-6-3:2007	Electromagnetic compatibility (EMC) - Part 6

Skive, 20/08-2018

Product manager

Lars Brodersen
VP Sales

Overview

Introduction

This is the service manual for the Dantherm A/S AC-24 unit.
The below table of contents gives an overview of the main sections.

This manual is for the unit AC 24

Dantherm Number	Code	NSN
323043	AC-24-B-305-R9010 *	4120-22-631-1514

**) The code is specified on the data plate, which is placed on the control panel.*

See the explanation of the syntax code on page 8

WARNING



It is the responsibility of the operator to read and understand this service manual and other information provided and to use the correct operating procedures. Air conditioners should only be operated by qualified (trained) personnel and the repair of the cooling circuit and electrical system is to be done only by skilled service people. Failure to do so can result in personal injury or equipment damage. Read the entire manual before the initial start-up of the air conditioner. It is important to know the correct operating procedures for the air conditioner and all safety precautions to prevent the possibility of property damage and/or personal injury.

Table of main topics

This service manual covers the following main topics:

Topic	See page:
General information	4
Table of content	5
Product description	6
User's guide	20
Service guide	29
Technical information	45

General information

Introduction	<hr/> <p>This section gives the general information about this service manual and about the unit.</p> <hr/>
Target group	<hr/> <ul style="list-style-type: none">• Users of the unit• Technicians who install and maintain the unit <hr/>
Part number	<hr/> <p>Part number of this service manual is 097881</p> <hr/>
Copyright	<hr/> <p>Copying of this service manual, or part of it, is forbidden without prior written permission from Dantherm A/S.</p> <hr/>
Reservations	<hr/> <p>Dantherm A/S reserves the right to make changes and improvements to the product and the service manual at any time without prior notice or obligation.</p> <hr/>
Recycling	<hr/> <p>The unit is designed to last for many years. When the time comes for the unit to be recycled, the unit should be recycled according to national regulation to protect the environment.</p> <hr/>
Quality Management System	<hr/> <p>Dantherm S.p.A has implemented a Quality Management System according to EN/ISO9001.</p> <p>The system is supplemented with an Environmental Management System according to EN/ISO14001. Both systems are approved by third party and certified, by Bureau Veritas Certification.</p> <p>During 2005 & 2006 the Management Systems were supplemented with business routines with regards to safety. These routines meet the requirements stated in the international standard for Safety Management Systems OHSAS18001.</p> <hr/>

Table of contents

Table of content

Product description	See page
General description	8
Transport of the unit	8
Description of parts	8
Syntax	9
Description of the cooling system	10
Description of the control board	15
Description of room thermostat	17
Description of the high and low pressure switch function	18
Functional Description	19
User's guide	
Preparations	21
Setup	22
Recommended camp configuration	23
Transport of the unit	26
Starting up and shutting down the air conditioner	27
Reset of thermo relay and control circuit fuse	28
Service guide	
Preventive maintenance	30
Spare parts	33
Fault finding guide	41
Service agreement	43
Technical information	
Technical data	45
Dimensions	46
Wiring diagram, AC 24	47
Wiring diagram reference	49

Product description

Introduction

This section will give you a description of the AC 24 and its functionality.

Content

The section covers the following topics:

Topic	See page
General description	8
Transport of the unit	8
Description of parts	8
Syntax	9
Description of the cooling system	10
Description of the control board	15
Description of room thermostat	17
Description of the high and low pressure switch function	18
Functional Description	19

General description

Introduction

This section describes the unit as a whole.
The following sections describe the different parts of the unit..

General

The AC 24 is a portable air conditioner that is made of high quality materials and the production process is subject to constant quality checking. The instructions in this service manual have been prepared to ensure that, when followed, this air conditioner will provide long and efficient service.

Typical applications

The AC 24 is designed primarily to supply cooled air to tents and other types of temporary portable shelters.

Functionality

The function of the unit is based on a cooling circuit and two powerful centrifugal fans. The lower section contains the evaporator and the evaporator fan which draws warm ambient or recirculated air through the cold evaporator coil and blows out the cooled air through the discharge.

The upper section of the unit houses the condenser fan and the condenser coil which returns the heat taken from the cooled air to the surrounding atmosphere.

WARNING



Do not cover, block or obstruct the air openings. This may cause malfunction!
Do not operate the product outside the specified temperature range.
See section "Technical data".

General description, continued

Illustration

This illustration gives an overview of the unit.

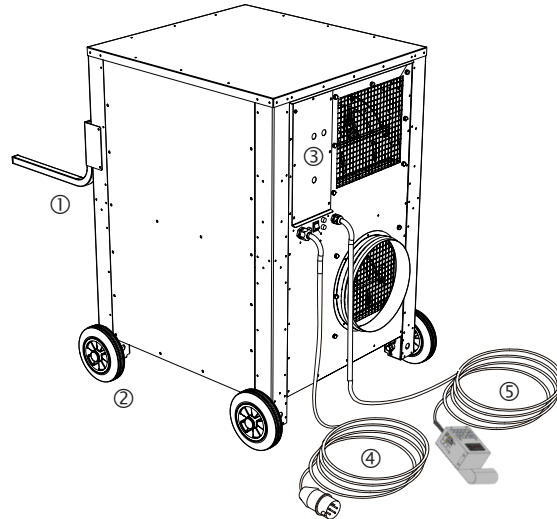

Parts

Item	Description
1	Handlebars for transport (Accessories)
2	Wheels for easy field mobility of the unit (Accessories)
3	Control panel with function switch and lamps
4	Mains cable
5	Room thermostat

Transport of the unit.

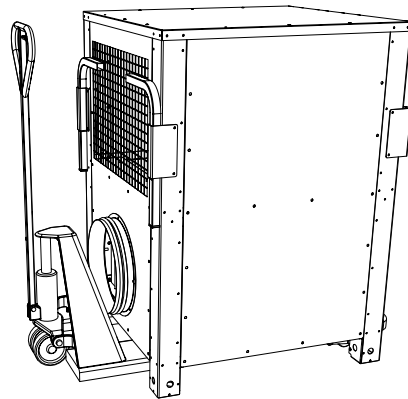

Syntax

Introduction

All products are named according to a syntax giving information about the specific unit configuration.

Example

This example is not necessarily related to the specific unit this manual describes:

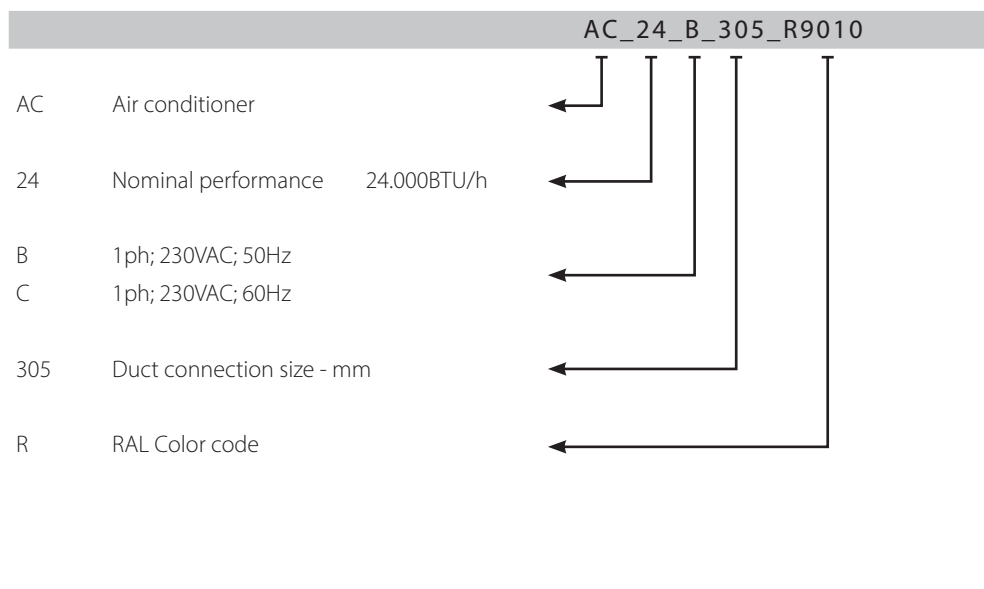

Description of parts

Introduction

This section gives a description of the following parts of the AC 24:

- Cabinet
- Air filters
- Heating coil
- Fans
- Mains cable
- Air openings

The following sections in this chapter give separate detailed descriptions of the cooling circuit, the control board and operation.

For illustration of the single components – please see section “General description”

Cabinet

The unit is made of strong construction in sheet metal plates which are galvanized to protect against corrosion.

The outside paint finish is standard white, RAL 9010.

In the middle plate there is a drain outlet for condensate.

On each side of the unit a plate can be removed to make inspection and service possible.

Inside the unit there is a horizontal partition dividing it into an upper and a lower section.

Fans

In both upper and lower sections there is a centrifugal fan with a direct-coupled motor.

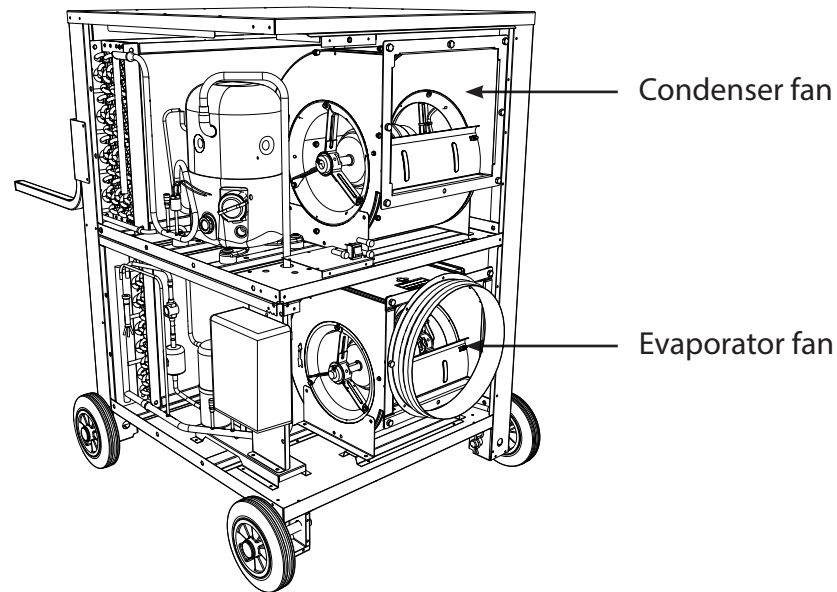

Air filters

The internal airflow enters through a standard washable, easily removable air filter, PPI 15. The filter is situated behind the return air inlet

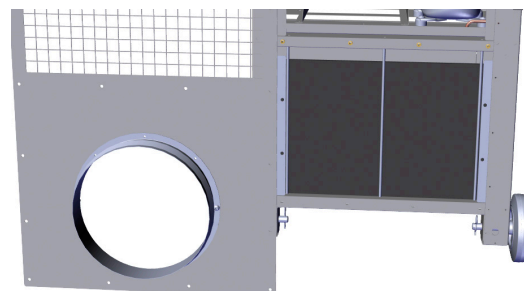

The rods keeping the filter in place are accessible through the fan opening without having to remove the cover.

The airflow will be influenced by the resistance in filters, hoses and coils, which must be kept clean to minimize the pressure drop.

Description of parts, *continued*

Mains cable

The unit requires an external electric power source.
The mains cable is 10 m long and normally has a 16 A CEE connector at its end.

Air openings

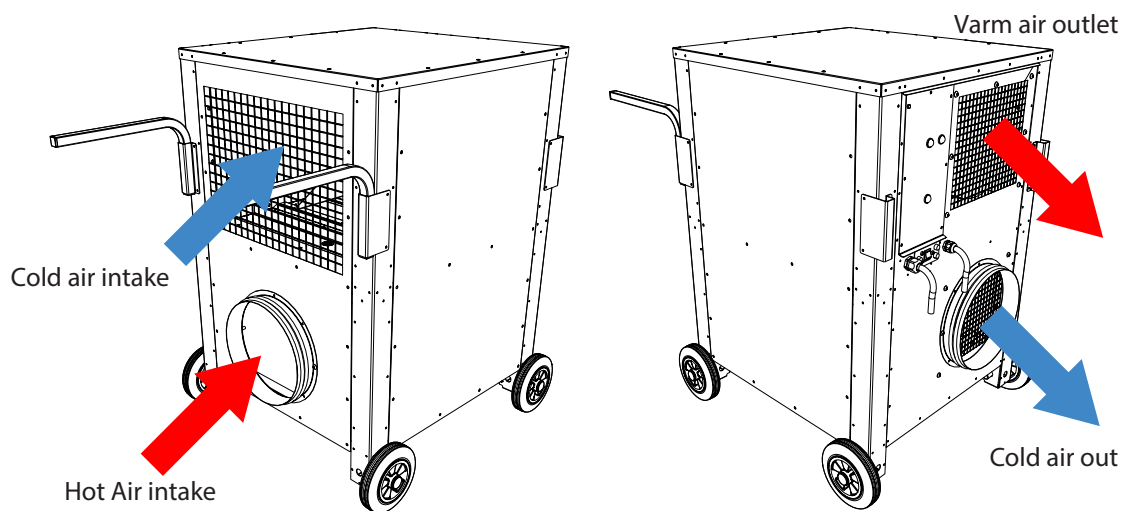

Description of parts, *continued*

Air openings, continued

inlets/outlets	Purpose
Supply air outlet, 1 × 315 mm	Air is supplied to the tent/shelter through these openings. Flexible air hose(s) will be connected here
Return air inlet, 1 × 315 mm	Air is drawn into the unit through this/these opening(s). With connected air hose(s) the unit is supplied with recirculated return air from the tent/shelter. Flexible air hose(s) will be connected here
Ambient air inlet	Ambient air is ducted in through the condenser after entering the external removable filter
Exhaust air outlet	Condenser exhaust air leaves the air conditioner through these openings

WARNING



Do not cover or obstruct air openings!

Description of the cooling system

Illustration

This drawing illustrates the different parts of the cooling circuit and where they are situated in the AC 24 unit:

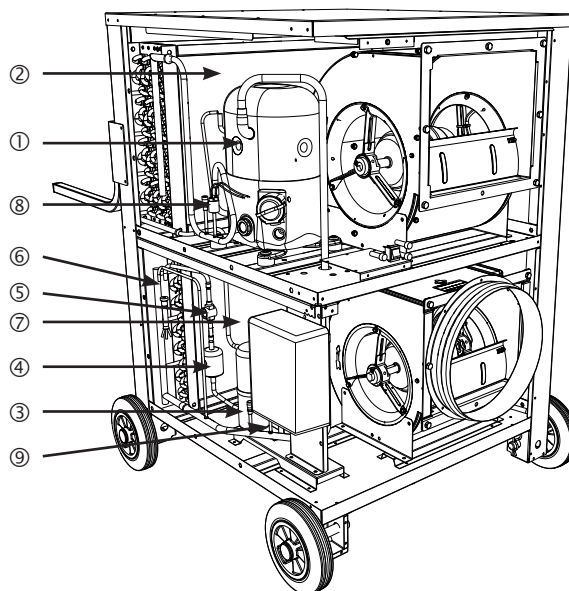

Parts and their function

This table gives an overview and short description of each part shown above and on the next page:

①	Compressor	Circulates the fluid in the cooling system
②	Condenser	Emits the heat generated in the tent/room to the outside air
③	Receiver	Accumulates surplus coolant in connection with the cooling process
④	Dry filter	Absorbs moisture and impurities in the cooling circuit
⑤	Sight glass	Enables a visual check of the coolant
⑥	Expansion valve	Supplies the correct quantity of coolant into the evaporator. It also reduces the pressure
⑦	Evaporator	Absorbs heat from the shelter by cooling down the circulated air
⑧	HP pressure switch	Ensures that the compressor does not operate at too high pressure
⑨	LP Pressure switch	Ensures that the compressor does not operate at too low pressure

Refrigerant

The cooling circuit is hermetically sealed and filled with refrigerant (R134a).

Liquid flow

From the receiver ③ liquid refrigerant will flow under high pressure through the liquid line dryer and the sight glass to the thermostatic expansion valve which releases the pressure. Here the refrigerant is led into the evaporator ⑦ where it evaporates under low pressure and low temperatures.

The evaporated refrigerant is drawn back to the hermetic compressor and compressed. From the compressor the refrigerant vapour goes to the condenser, where it is cooled to below the dew point and condensed to liquid refrigerant.

Description of the cooling system, *continued*

Description

Both evaporator and condenser are heat exchangers with copper tubes and aluminium coated fins. By the cooling of the evaporator air stream heat is adapted to the cooling circuit and released in the condenser together with the electric energy consumption of the compressor. At room temperatures below 20 °C, where cooling is not normally required, the humidity in the airflow will form ice on the evaporator. To prevent this, the LP pressure switch cuts out at low pressure in the circuit. If the room temperature is too low, the LP activation will cause the compressor to start and stop frequently. This may damage the compressor and must be avoided at any time by not operating the product outside the specified temperature range. See section "Technical data", page 45. At high ambient temperatures (above 55 °C) the cooling of the condenser airflow will be too poor, and the high pressure results in cut out of the HP pressure switch.

The yellow lamp on the front panel will illuminate if the HP/LP pressure switch cuts out. The HP/LP pressure switch automatically resets after a few minutes and the lamp will switch off again. If the lamp continues to illuminate, please refer to the "Fault finding guide", page 41.

Schematic view

This schematic drawing illustrates the different parts of the cooling circuit.

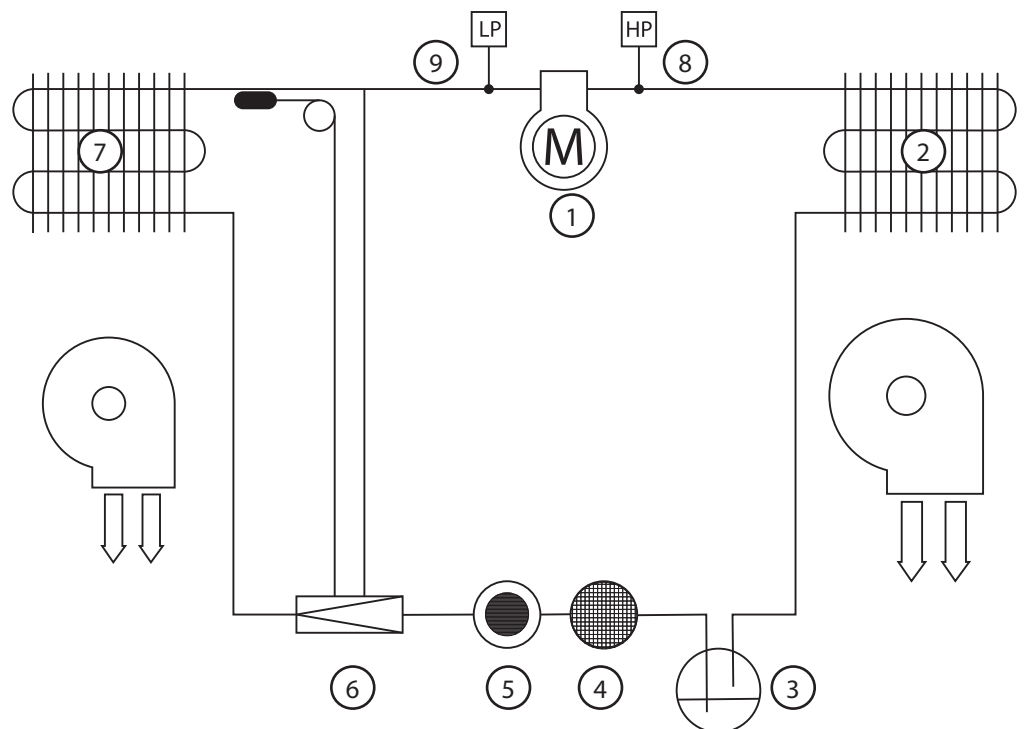

①	Compressor	⑥	Expansion valve
②	Condenser	⑦	Evaporator
③	Receiver	⑧	HP pressure switch
④	Dry filter	⑨	LP pressure switch
⑤	Sight glass		

Description of the control board

Introduction

This section gives a description of the control board.
A description of how to start up, for example, is found in the relevant sections.
The control panel on the front contains the controls required for normal operation.

Illustration

This drawing illustrates the control board of the AC 24:

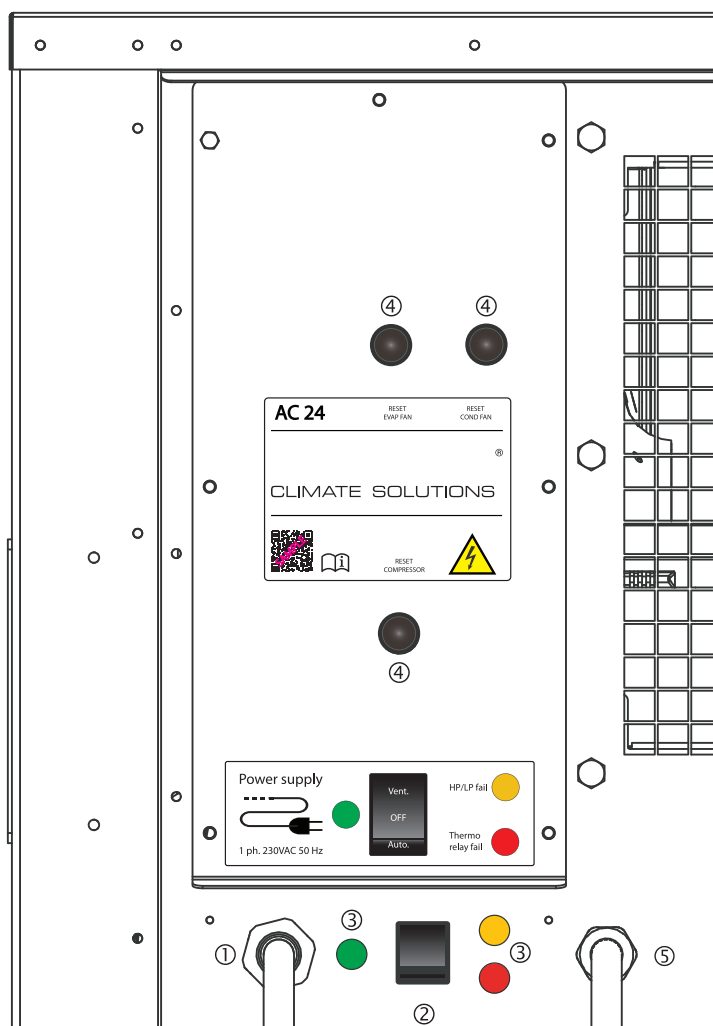

See references on next page.

Description of the control board, *continued*

Part/function

This table gives an overview of each part of the control panel in fig. 6:

No	Part	Function												
①	Electric connection	Mains cable with a 16 A CEE connector at the end												
②	Function switch	The function switch selects the operating mode and has three positions: VENT, OFF and AUTO												
③	Indicator lamps	On the operator panel there are three control lamps, indicating the following:												
		<table border="1"> <thead> <tr> <th>Color</th> <th>Unit</th> <th>Description</th> </tr> </thead> <tbody> <tr> <td>Green</td> <td>Power</td> <td>Shows that power has been connected to the unit</td> </tr> <tr> <td>Red</td> <td>Thermo relay fail</td> <td>Illuminates if the compressor, evaporator fan or condenser fan thermo relay has cut off because of a too high running current. Please also refer to the "Fault finding guide"</td> </tr> <tr> <td>Yellow</td> <td>HP/LP</td> <td>Illuminates when the built-in HP/LP pressure switch cuts out and stops the compressor because of too high pressure (HP) or low pressure (LP) in the cooling circuit. The HP/LP pressure switch automatically resets after a few minutes. Do not let the product operate with HP/LP switching ON and OFF. If the lamp continues to illuminate, please refer to the "Fault finding guide"</td> </tr> </tbody> </table>	Color	Unit	Description	Green	Power	Shows that power has been connected to the unit	Red	Thermo relay fail	Illuminates if the compressor, evaporator fan or condenser fan thermo relay has cut off because of a too high running current. Please also refer to the "Fault finding guide"	Yellow	HP/LP	Illuminates when the built-in HP/LP pressure switch cuts out and stops the compressor because of too high pressure (HP) or low pressure (LP) in the cooling circuit. The HP/LP pressure switch automatically resets after a few minutes. Do not let the product operate with HP/LP switching ON and OFF. If the lamp continues to illuminate, please refer to the "Fault finding guide"
		Color	Unit	Description										
		Green	Power	Shows that power has been connected to the unit										
Red	Thermo relay fail	Illuminates if the compressor, evaporator fan or condenser fan thermo relay has cut off because of a too high running current. Please also refer to the "Fault finding guide"												
Yellow	HP/LP	Illuminates when the built-in HP/LP pressure switch cuts out and stops the compressor because of too high pressure (HP) or low pressure (LP) in the cooling circuit. The HP/LP pressure switch automatically resets after a few minutes. Do not let the product operate with HP/LP switching ON and OFF. If the lamp continues to illuminate, please refer to the "Fault finding guide"												
④	Reset button •Compressor •Evaporator fan •Condenser fan	If the failure indicator (Thermo relay ③) illuminates, the thermo relay will have to be reset on one of the reset buttons. If it is not clear which one of the thermo relays has disconnected, push the reset buttons one by one. See also "Fault finding guide"												
⑤	Thermostat connection	Cable for the remote thermostat												

Description of room thermostat

Introduction

This section gives a description of the room thermostat.

Illustration

This drawing illustrates the different parts of the room thermostat:

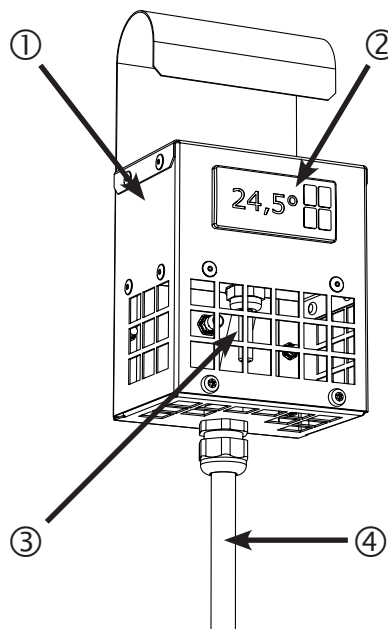

For instructions on how to operate the thermostat controller, see page 23

Parts and their function

No	Part	Function
①	Chassis	Housing with hanger for suspension.
②	Thermostat controller	Setting the parameters for the room thermostat.
③	Sensor	Measures the temperature
④	Cable	15m

Location

The thermostat must be placed inside the tent. See more about the placement in section "Set-up"

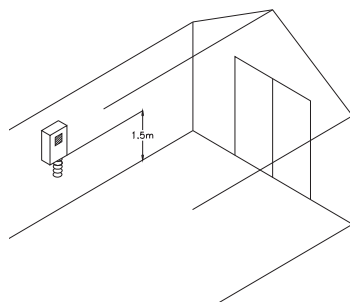

Description of the high and low pressure switch function

Introduction	This topic describes the HP/LP function.
System protection	The cooling system is protected by pressure switches. If the pressure falls outside of the normal operating range, the air conditioner compressor is automatically switched off. This is to prevent component damage. If the pressure is too high or too low, the unit is switched off. The malfunction must normally be identified by a trained technician and corrected.
Reset	The HP/LP pressure switch automatically resets after a few minutes. If the lamp continues to illuminate, please refer to the "Fault finding guide".
LP (low pressure)	<p>The cooling system is protected by a low-pressure switch (LP switch). The switch is set at 1 bar and will automatically reset at 2.5 bar. The safety function cuts off the compressor.</p> <p>The LP function will be activated if:</p> <ul style="list-style-type: none">• The cooling system loses refrigerant• The internal temperature is so low that the low pressure gets below set point (1 bar). <p>Do not operate the product with frequent operating LP function.</p> <ul style="list-style-type: none">• The evaporator is blocked or does not get sufficient air flow
HP (high pressure)	<p>The cooling system is protected by a high-pressure switch (HP switch). The switch is set at 25 bar and will automatically reset at 18 bar. The safety function cuts off the compressor.</p> <p>The HP function will be activated if:</p> <ul style="list-style-type: none">• The outdoor temperature is too high• The condenser is blocked or does not have sufficient airflow

Functional description

VENT
Ventilation-only
operation

With the function switch in this position the evaporator fan will operate continuously and the cooling unit, heating coil (if installed) and condenser fan will be turned off. This mode can be used to bring in fresh outdoor air or to recirculate the indoor air - even when cooling or heating (if installed) is not needed.

AUT. or AUTO
Room thermostat
operation, cooling/
heating (if installed)

With the function switch in this position, the unit will operate according to the room thermostat settings.

On the AC 24 with heating coils the room thermostat has a flip switch with the following positions:

- Cool

With the flip switch in the cool position, the unit will cool as long as the thermostat senses a temperature higher than the set point. When the temperature reaches the set point it cuts off the compressor and condenser fan.

OFF or 0

OFF

With the function switch in this position all functions will stop immediately and only the illuminated green lamp will indicate that the power is still on if the main switch is on.

User's guide

Introduction

This section describes how to utilise the different functions.

WARNING



Do not try to restart the compressor several times within a short period. This will make the compressor overheat and may damage it. The internal compressor thermostatic protection may also cut out. Operating the product outside the temperature range specified in the technical data will cause the cooling system to start frequently. Do not operate the product at temperatures outside the specifications.

WARNING



If forklift (MHE) is to be used it is imperative that the tine is fully engaged, thereby supporting the entire unit. Rough and incorrect handling can cause damage and loss of function.

Contents

This User`s guide contains the following topics:

Topic	See page
Preparations	21
Setup	22
Operating the room thermostat	23
Recommended camp configuration	24
Starting up and shutting down the air conditioner	27
Reset of thermo relay and control circuit fuse	28

Preparations

Location

Follow these conditions when siting the air conditioner:

Conditions
Place in the shade as close as possible to the tent/shelter that needs to be ventilated
Place the air supply ducts in both ends of the tent/shelter
Allow sufficient space around the air conditioner for operating and servicing access
Avoid sharp bends or kinking when locating air supply ducts in order to avoid disruption of the airflow (see "Recommended camp configuration", page 24)
Keep any source of engine exhaust fumes (vehicles/generators etc.) away from air in-takes

Air distributing channels

It is imperative that the cooled air is distributed equally inside the tent/shelter. For that purpose the use of air distributing hoses are recommended (accessory).

Power

The air conditioner requires 1 x 230 V AC/50 Hz.

The mains cable is 10 m long and has a 16 A CEE connector at the end.

Note

The maximum combined length of flexible air hoses should not exceed 9-10 m.

Setup

Procedure

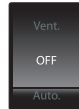
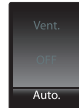
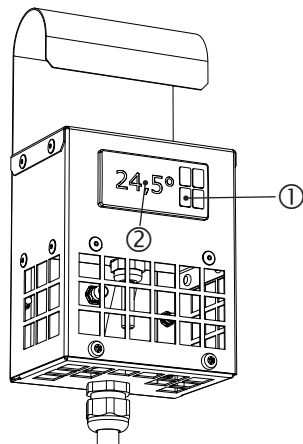
Step	Action
1	Find a suitable location for the air conditioner as described on previous page.
2	<p>Supply ducts. Connect the flexible air hoses to the evaporator discharge openings (Cold air out) and insert the opposite end of the hose to the tent. If there are any internal distribution hoses in the tent, these can also be connected.</p>
3	<p>Return ducts. A return air hose may be connected from the shelter to the evaporator air inlet (hot air intake) As long as the return air is colder than the ambient air, this will save cooling capacity.</p>
4	<p>Place the room thermostat inside the tent/shelter at the optimal location.</p> <ul style="list-style-type: none"> • Avoid sunlight • Avoid direct cold air from the air conditioner ducts • 1.5 m above the floor • Near the return air end of the tent/room
5	<p>Make sure that the function switch is set to „OFF“</p> 
6	Connect the CEE plug to an external power source.
7	<p>Set function switch to "Auto" and the unit will run using the room thermostat.</p> 
8	<ul style="list-style-type: none"> • Set the desired temperature ② in the shelter by pressing the buttons ① on the thermostat. <p>Operating range in cooling mode: 20°C to 50°C</p> <p>See the section: Description of room thermostat on page 17.</p> 

Operating the room thermostat

Quick guide

This section gives a quick introduction on the use of the room thermostat. :

Function button on the unit

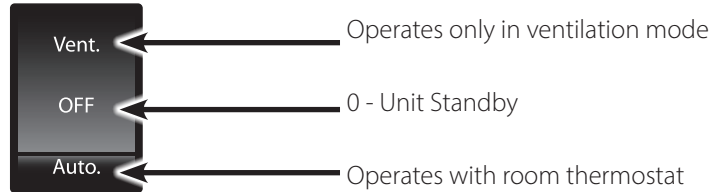

Room thermostat: Adjusting the setpoint temperature.

Turn on thermostat controller if off

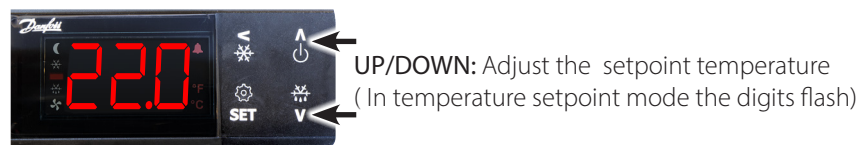
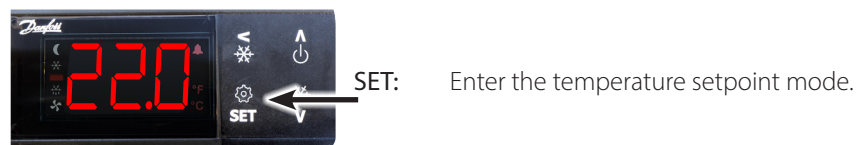

Reset to factory settings

- Disconnect the power from the unit.
- Press and hold the two buttons shown below.
- Power up the unit - with the buttons pressed.

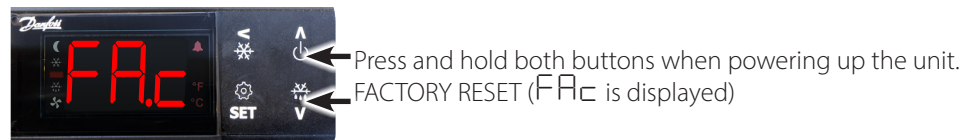

Note: Above mentioned factory reset does only apply on units with serial numbers after 1810000000000.

Contact Dantherm for thermostat controller factory settings for units with serial numbers below 1810000000000.

Recommended camp configuration

Introduction

The configuration is an important factor for gaining the highest performance and reliability from the air conditioner including lowest power consumption. A camp can be set up in various ways and still work, but a few important hints will be given in this section.

This section describes the following:

- Ducting
- Solar heat
- Air distribution
- Sand storms
- Air re-circulating
- Doors and openings
- Heat sources
- Surroundings
- Drains

Ducting

The ducts will introduce a pressure loss every time they are bent. Slight bends are not as critical as tight bends > 45°.

The shorter the ducts the higher performance from the air conditioner.

In some cases the tent does not allow for ducting as per the air conditioner design. Be aware that blocking one or two of the duct holes on the air conditioner will reduce the cooling performance significantly.

Use as few ducts as possible. As a rule of thumb expect that each 3 m insulated duct changes the temperature inside the duct by 3-5 °C (6-10 °F).

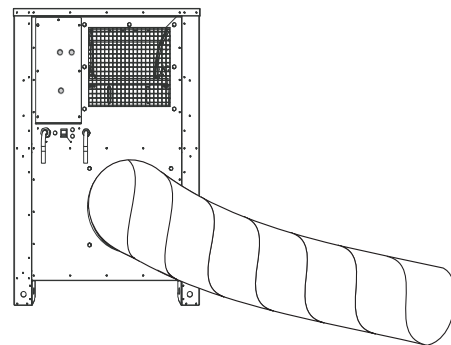
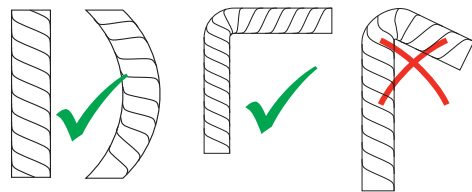

Solar heat

Solar heat gain to shelter surfaces and to duct-/air conditioner reduces the efficiency of the unit. If possible use a sun shield to cover the shelter, the air conditioner, and the associated air ducting. Additional efficiency is gained by using insulated panels/liners in the shelter.

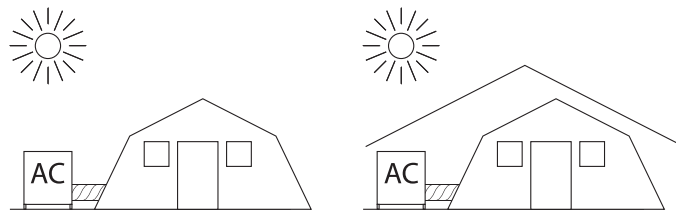

Recommended camp configuration, *continued*

Air distribution

In cases where air distribution plenums are used for distributing the internal cooled air, it can be an advantage if the plenum is located under the roof. The cold air will slowly fall to ground and be sucked back into the air conditioner.

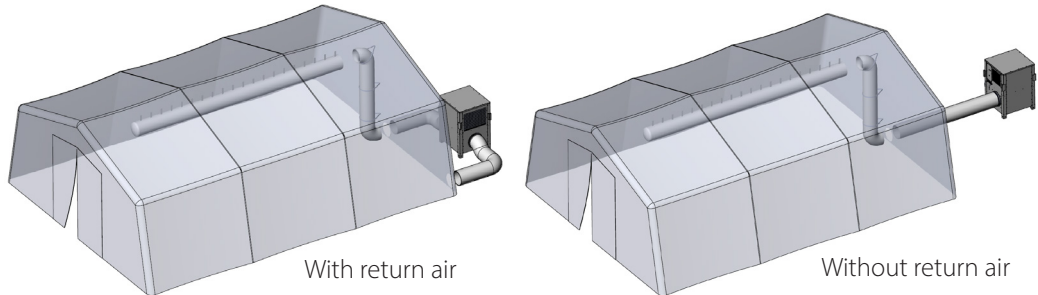

Sand storm

In case of sand storms it is important that the air conditioner is shielded against the sand. Do not shield to the extent where the air flow will become obstructed.



Air re-circulating

In order to cool down the air most efficiently, the air being introduced to the air conditioner must be as cold as possible. If the room temperature is lower than the ambient temperature outside, it is most efficient to re-circulate the air from the room. To do so, connect insulated ducts between the tent and the air conditioner internal air in-take.

If the tent temperature is higher than the ambient temperature, it can be an advantage to operate without return ducts. Also be aware of the dust risk and generation of over pressure in the tent.



Doors and openings

In order to achieve best performance it is imperative that doors and openings are kept closed.

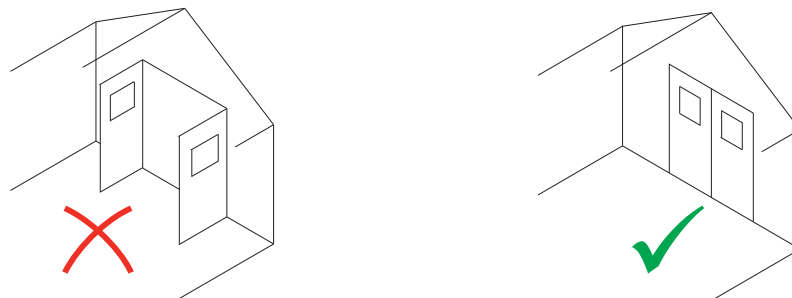

Recommended camp configuration, *continued*

Heat sources

Heat producing sources will degrade the efficiency of the air conditioner and thus non-essential heat sources should be turned off whenever possible.

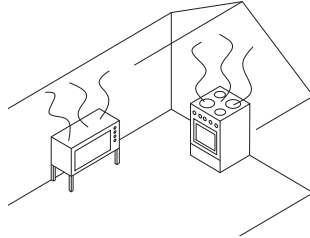

Surroundings

Do not cover, block or obstruct the air path. Make sure that the air conditioner is clear of obstruction on all sides allowing air to be drawn in and exhausted out freely.

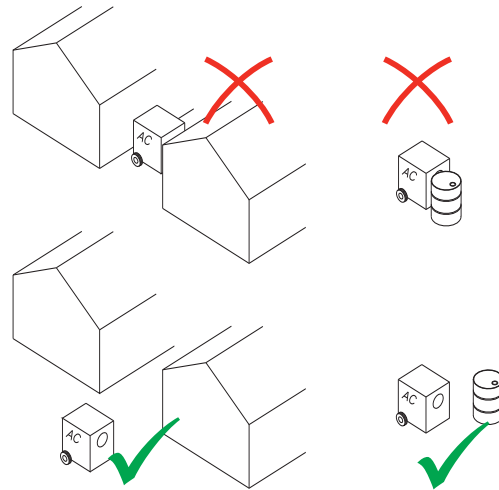

Drain

Water draining from the evaporator will saturate the area around the drain outlet. Pay attention to this potential problem and route away condensate if necessary. If possible raise the air conditioner above ground level by use of a pallet or other suitable means.

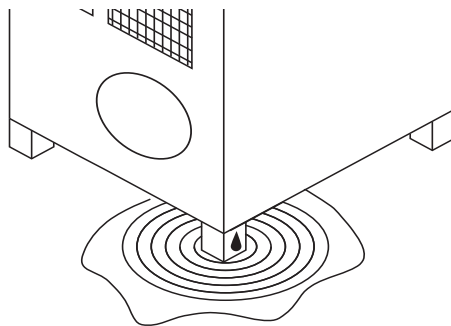

WARNING

Do not park vehicles where exhaust gases can be drawn into the air intake of the AC-24

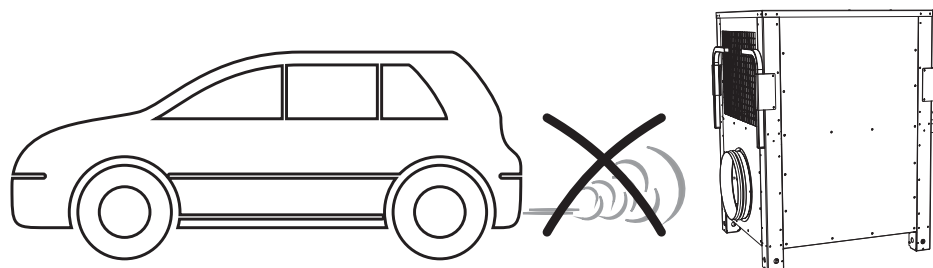

Starting up and shutting down the air conditioner

Start up

After preparation and set-up the air conditioner is ready for operation.

Turn the function switch to the desired mode (see "Description of the control board", page 15) and the unit will operate according to the "Functional description",

Fault

If the unit does not operate it might have been switched off by a safety device:

- HP pressostat: High ambient temperature stopped condenser fan or reduced airflow over the condenser
- LP pressostat: Low return air temperature stopped evaporator fan or reduced airflow over the evaporator
- Evaporator or condenser thermo relay: Running current for fan motor too high
- Compressor thermo relay: running current for compressor too high
- ETA relay: running current for control current too high

Refer to the "Fault finding guide", for possible solutions.

WARNING



Do not attempt to repeatedly restart the compressor.

This will cause the compressor to overheat and may damage it.

The internal compressor thermostatic protection may also cut out.

Shutting down

Follow this procedure to shut down the air conditioner from any mode of operation:

1. Turn the function switch to OFF/0
Result: All operations will stop immediately
 2. Disconnect the connector from the power source if any servicing has to be performed.
If the air conditioner is not to be re-used for a long period, continue shutting down as follows:
 3. Disconnect the air ducts and stow them in their compression sacks.
-

Reset of thermo relay and control circuit fuse

Introduction

The procedures below describe how to reset the thermo and replace the control circuit fuse.

Thermo relay

If the running current for the compressor, condenser fan or evaporator fan exceeds the set value, the thermo relay will switch off the compressor or fan and will have to be reset.

Reset Thermo relay

Push the buttons one by one in no particular order to reset the thermo relay. See buttons marked with arrows below.

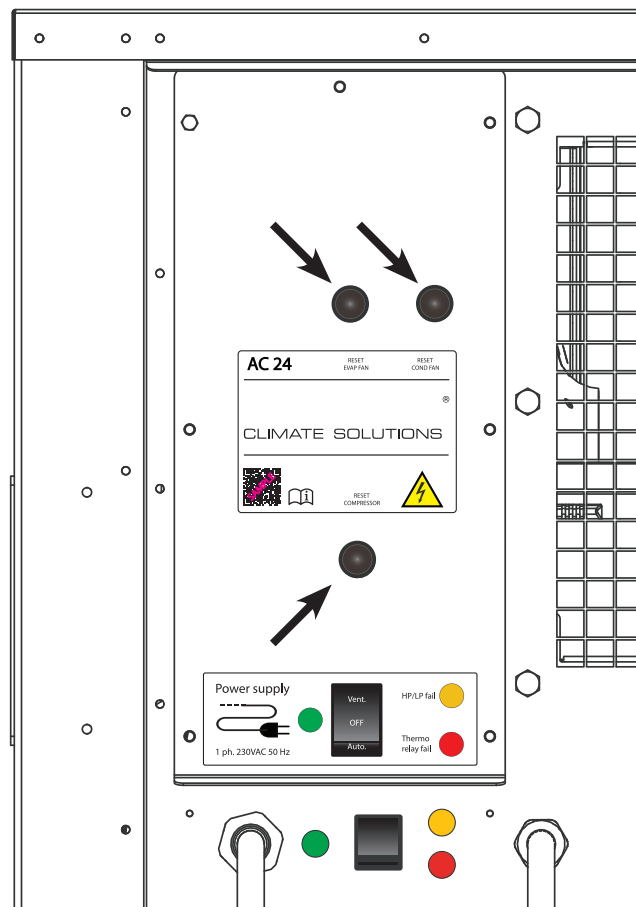

Control circuit fuse

If the running current for the control circuit is too high, the fuse will blow, and will have to be replaced. See location below.

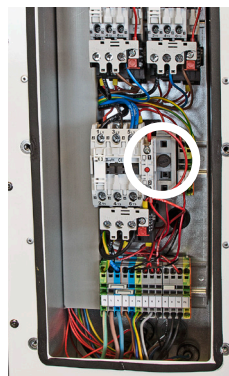

Service guide

Contents

Topic	See page
Preventive maintenance	30
Spare parts	33
Fault finding guide	41
Service agreement	43

Preventive maintenance

Introduction

In order to achieve the best possible operation and long lifetime of the air conditioner it has to be maintained properly within defined guide lines.

This section contains the description of daily, monthly and annual maintenance.

Tools

For service and maintenance no special tools are required.

A 10 mm spanner and a flat headed screwdriver are sufficient for most maintenance tasks.

CAUTION

Before doing any maintenance, be sure that the air conditioner has been shut down and that the power cable is disconnected from the unit.

See section "Starting up and shutting down the air conditioner"

Daily preventive maintenance

Preventive maintenance to be carried out daily or every 8 hours of operation:

After shutdown each day or after every eight hours of operation perform the following preventive maintenance procedures:

Daily preventive maintenance

Preventive maintenance to be carried out daily or every 8 hours of operation:

After shutdown each day or after every eight hours of operation perform the following preventive maintenance procedures:

Step	Action
1	Inspect electrical cables for damage or loose connections
2	Inspect the air filter and remove any debris or foreign objects that may have accumulated on filters.
3	Inspect air hoses for damage or sharp bends

Preventive maintenance, *continued*

Monthly preventive maintenance

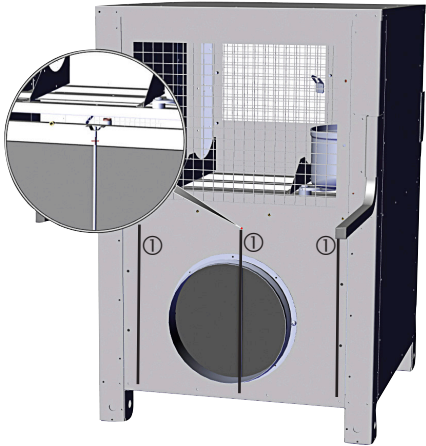
Step	Action
1	Perform daily maintenance as described on previous page.
2	<p>Remove the air filter which have to be vacuum cleaned or washed in lukewarm soapy water.</p> <p>The evaporator filter is easily removed. In order to remove the filter material, Remove the three flexible plastic rods holding the filter in place ①. Access the rods through the duct hole. Make sure that the filter is dry before it is returned to service and are subjected to dust.</p>
	
3	Remove the two side cover plates and inspect the evaporator and condenser coils. If they are dirty vacuum clean or wash with warm soapy water and a brush
4	Check that the condensate drain is not blocked
5	Inspect and clean the radial wheels in the two fans if necessary

Annual preventive maintenance

Step	Action
1	Perform daily and monthly maintenance as described
2	Have a refrigerant mechanic check the cooling circuit and all electrical functions This control must follow the national rules for control of cooling equipment.

Spare parts

Introduction

This section contains the general information needed when ordering spare parts.

For units in military services spares will normally be ordered through the military logistic system.

When ordering

When ordering, kindly inform us about:

- Dantherm S.p.A. spare parts number/text
- NATO stock number of parts
- Dantherm S.p.A. field unit type
- Dantherm S.p.A. production and serial number from the data plate of the field unit (or approximate date of delivery).

Information

If it is part of a group naturally forming a whole or part of a purchased, complete component, some items may not be available for individual delivery.

Dantherm S.p.A. reserve the right to make this assessment.

Reservations

Dantherm S.p.A. reserve the right to make any necessary changes of construction and choices of components without notice - but will, as far as possible, maintain a stock of the changed parts.

Contents

Topic	Page
Spare parts for cabinet	34
Spare parts for cooling system	36
Spare parts for controller	38
Accessories	40

Spare parts for cabinet

Illustration

Available spare parts

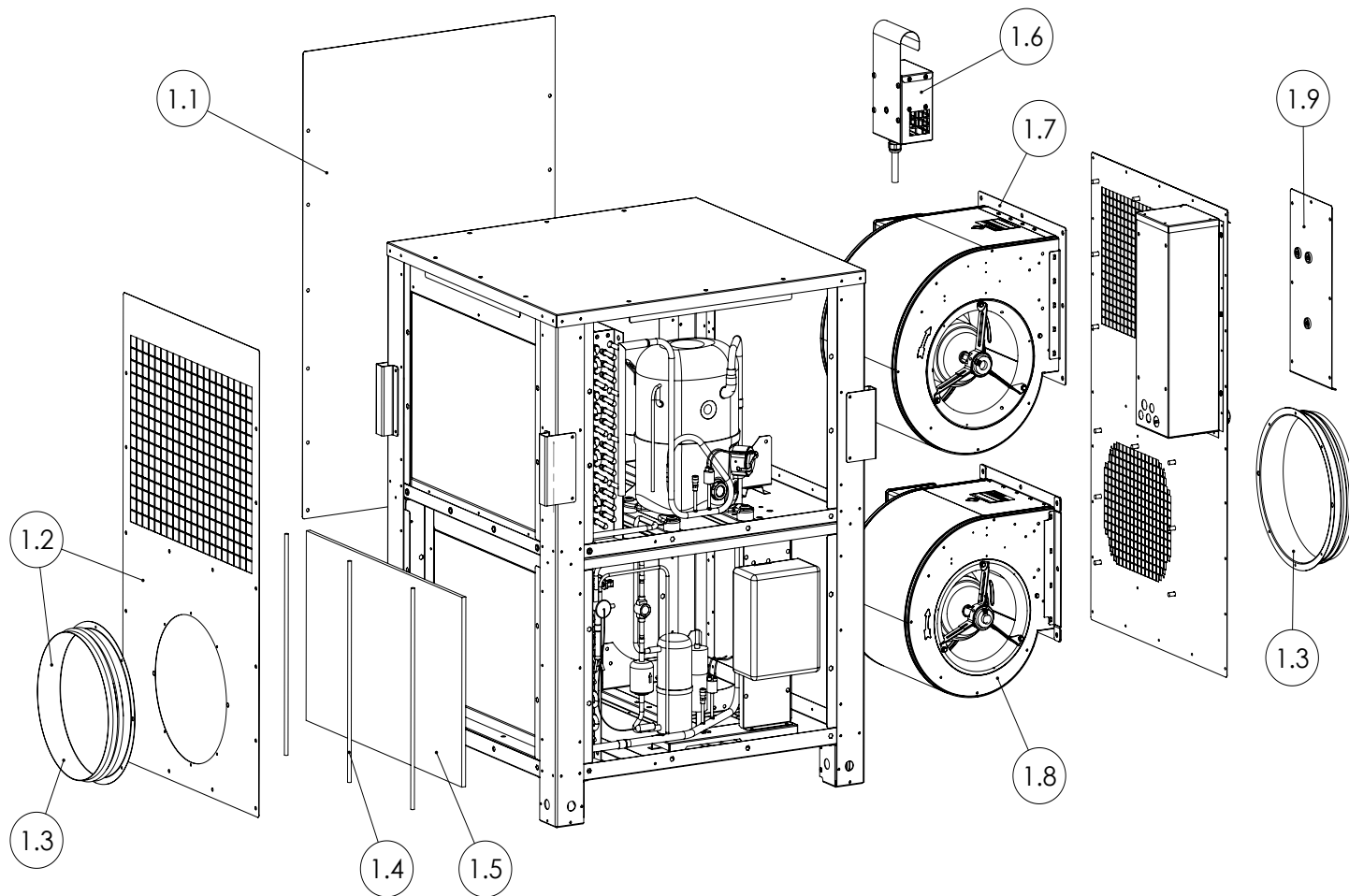

Spare parts for cabinet

Cabinet

Cabinet	Art.No.	Name	NSN
1.1	098820	Sideplate right/left	4130-22-632-1603
1.2	098822	Rear plate with hose connection	4130-22-632-1606
1.3	098823	Hose connection	5999-22-632-1609
1.4	098824	Filter mounting	5340-22-632-1612
1.5	081579	Filter	4130-22-632-1614
1.6	093803	Roomthermostat complete.	5930-22-632-1619
1.7	081582	Condenser fan	4140-22-632-1622
1.8	075499	Evaporator fan	4130-22-632-1626
1.9	098830	Front for controller	4130-22-632-1664

Spare parts for Cooling system

Illustration

Available spare parts for cooling system

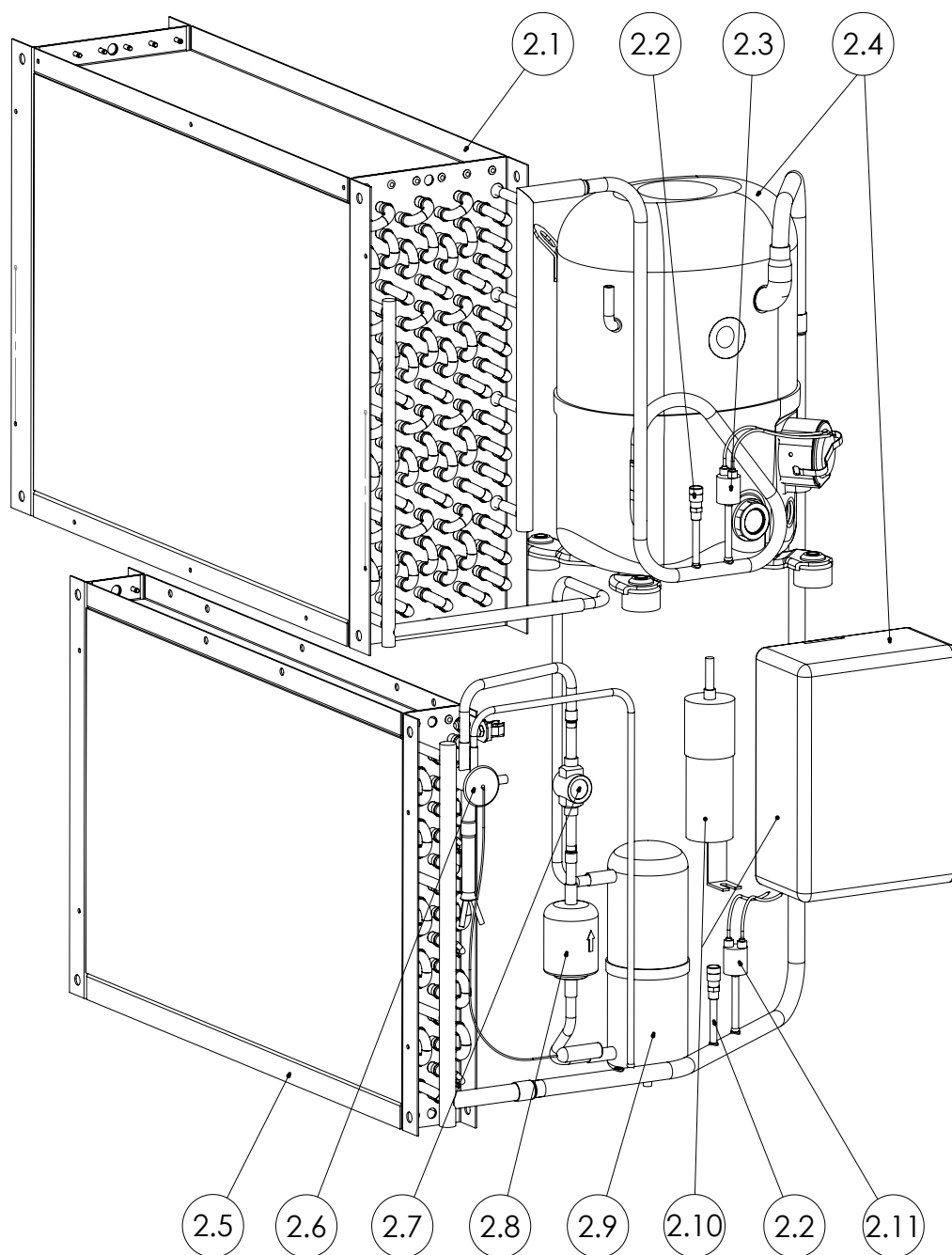

Spare parts for Cooling system

Cabinet

Cabinet	Art.No.	Name	NSN
2.1	081580	Condenser coil	4130-22-632-1665
2.2	063125	Service valve	4820-22-632-1667
2.3	298976	Low Pressure switch (LP)	5930-22-632-1668
2.4	098840	Compressor cpl. incl. electrical box	4130-22-632-1670
2.5	091283	Evaporator coil	4130-22-632-1672
2.6	081631	Thermostatic valve	4820-22-632-1677
2.7	063123	Sight glass	6680-22-632-1679
2.8	298974	Filter drier	4130-22-616-3541
2.9	063128	Reciever	4130-22-632-1682
2.10	099358	Electrical box for compressor, cpl. incl. capacitors and relay.	5975-22-632-5169
2.11	086414	High Pressure switch (HP)	5930-22-632-1684

Note: All spare parts for cooling system includes filter drier.

Spare parts for Controller

Illustration

Available spare parts for controller

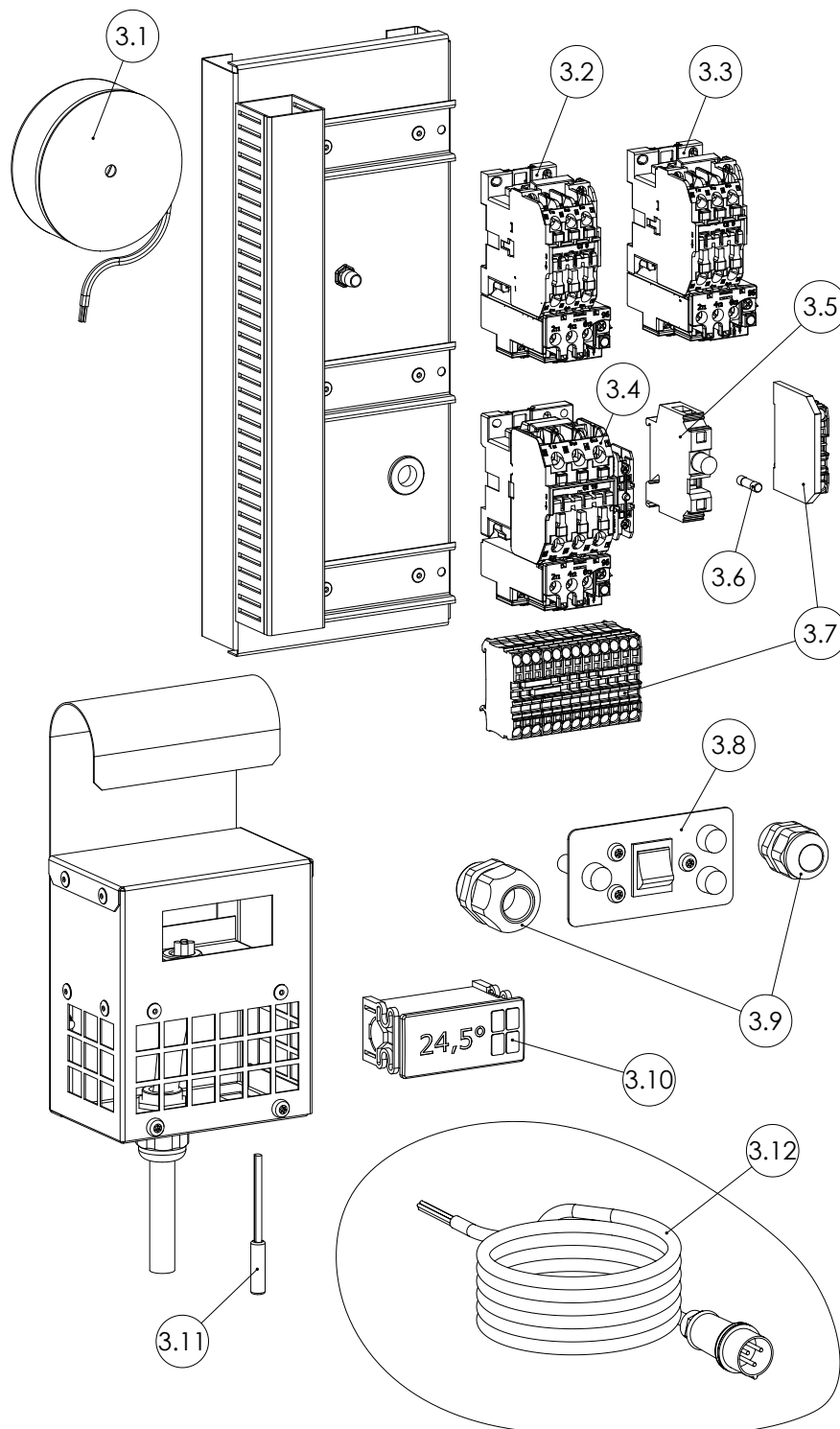

Spare parts for Controller



Cabinet

Cabinet	Art.No.	Name	NSN
3.1	081686	Transformer	6120-22-632-1689
3.2	098858	K1 - Contactor Cpl.	6110-22-632-1709
3.3	098859	K2 - Contactor Cpl.	6110-22-632-1710
3.4	098860	K3 - Contactor Cpl.	5945-22-632-1712
3.5	098861	Fuse Block	5920-22-632-1713
3.6	098862	Fuse 10 pcs.	5925-22-632-1714
3.7	098863	Terminal block cpl.	5940-22-632-1726
3.8	098864	Controller front	1670-22-632-1727
3.9	064274	Cable gland set	5975-22-620-1668
3.10	091287	Controller for Roomthermostat	4130-22-632-1696
3.11	091288	Sensor for Roomthermostat	6685-22-632-1698
3.12	098865	Power supply cable	6150-22-632-1699

Accessories

Accessories

Art. No.	Description	Illustration	Nato Stock Number
096673	Wheel set and handles	 <p>4x 2x</p>	4520-22-631-7709
097754	Hose Ø320mm L. 3000mm		4720-22-631-7710
097756	Air distribution hose Ø320mm L. 5000mm		4720-22-631-7163
098108	Hose ties	 <p>3x</p>	5340-22-631-7711
093894	Handles	 <p>2x</p>	5340-22-631-7708

Fault finding guide

Fault finding

Malfunctions that might occur in the operation of the air conditioner are listed in the table below. Reference to actions required to restore the air conditioner to normal operating condition are also indicated.

If the air conditioner should malfunction, find the problem in column 1. Columns 2 and 3 describe the possible causes and corrective actions. The list of problems, causes, and remedies will only give an indication of where a possible problem can be and what actions are needed to correct the problem.

Problem ①	Cause ②	Action ③
Air conditioner does not operate Green indicator lamp on control panel is not ON	No power input	Check that the power cable is correctly connected to power source and unit. Check that power source is turned on and providing 1 x 230 V AC
	The unit controller fuse is blown.	Replace fuse. Location shown on page 28
Air conditioner (compressor) does not operate. Green and yellow HP/LP indicator lamps are on, but they switch off again after a few minutes	High ambient temperature resulting in HP pressure switch cut-out	The HP pressure switch will automatically reset when the ambient temp. has fallen below 55 °C.
	Reduced condenser airflow perhaps combined with ambient temperature just below 55 °C	Hereafter the unit will restart
	Reduced evaporator airflow perhaps combined with low ambient temperature resulting in LP pressure switch cut-out	Clean evaporator coil and airflow filter Check that the grill at the air outlet are not blocked
	Faulty thermostatic valve	A refrigeration engineer has to replace the valve.
Air conditioner (compressor) does not operate. Green and yellow HP/LP indicator lamps are on, and they do not switch off after a few minutes	Refrigerant leak on the cooling circuit	A refrigerant engineer has to check on the problem
Compressor does not operate Green and red THERMO RELAY indicator lamps are on	Compressor thermo relay has cut off	Press the reset button for compressor on the control panel (see section "Reset of thermo relay", page 28)
	Thermostat controller is switched OFF	Turn on the thermostat controller. Press and hold 

Fault finding guide, *continued*

Fault finding, continued

Problem ①	Cause ②	Action ③
Condenser or evaporator fan does not operate.	Fan thermo relay has cut off	Press the reset button for the evaporator or condenser fan on the control panel (see section "Reset of thermo", page 28)
Green and red thermo relay indicator lamp are on		

WARNING



Do not try to restart the compressor several times within a short period. This will overheat and may damage the compressor. The internal compressor thermostatic protection may also cut out.

High ambient temperature

If the surrounding temperature is higher than the max working temperature: 55 °C, the condenser will not be cooled enough, resulting in too high pressure in the cooling circuit and thereby operating the pressure switch (HP). Allow some time for cooling of the system.

Low ambient temperature

If the air conditioner is operating below 20 °C the humidity in the airflow can form ice in the evaporator coil. As the ice is insulating, the pressure in the cooling circuit will decrease until the pressure switch (LP) operates. In this case the mode selector should be turned to ventilation-only so that the evaporator coil can be defrosted by the airflow.

Reduced airflow

A reduced airflow can be caused by dirty filters or sharp kinks in the air hoses etc. This can result in activation of the pressure switch (LP). Check the unit.

Error code thermostat controller

Error code **E29** in the thermostat controller display indicates Air temperature (Sair) sensor error. (Temperature sensor malfunction or loose connection.)

Service agreement

Introduction

The unit includes mechanical and electrical parts and the unit is often placed in a rough environment where the components are exposed to different climate conditions. Therefore the unit will need preventative maintenance on a regular basis.

The After Sales Support Department of Dantherm S.p.A. is ready to help you in case of a problem. To be able to offer quick and efficient help, please have the following information ready when contacting Dantherm S.p.A.:

- Name
- Company
- Country
- Phone no.
- Email
- Type (unit)
- Site/location (unit)
- Serial no/order no.
- Description of the problem

Contact Dantherm S.p.A. and ask for the After Sales Support department and help will be provided as soon as possible:

Phone: +45 96 14 37 00
Fax: +45 96 14 38 00
Email: service@dantherm.com

Preventive maintenance

Dantherm S.p.A. offers to do the preventive maintenance on the units so that they at all times will operate according to factory standards.

Corrective and emergency repair

In case of malfunctions of the product Dantherm S.p.A. offers to do emergency repair on the climate units. Agreements will be made with the customer on response time and price.

Setup

Dantherm S.p.A. has established a network of service partners to do the preventative maintenance. The partner is trained and certified on the actual climate units. The partner will also carry an adequate number of spare parts – so that any repairs can be made during the same visit. The agreement will be made with Dantherm S.p.A. – and the overall responsibility for the agreement belongs to Dantherm S.p.A.

Further information

For further information about a service agreement in your country or region, please contact:

Dantherm S.p.A.
Phone: +45 9614 3700
Email: support@dantherm.com
Website: support.dantherm.com

Technical information

Overview

This section provides technical information about the AS 24 and covers the following topics:

Contents

Topic	See page
Technical data	45
Dimensions	46
Wiring diagram, AC 24	47
Wiring diagram reference	49

Technical data

Introduction

Technical data for the AC 24 units.

*Note: All data regarding heating is only relevant for models with heating coil installed.

Performance characteristics

The air conditioner has a maximum cooling capacity of 6.0 kW.

When the relative humidity of the air inlet is high, the air can be cooled below its dew point and thus condense some of the water vapour to free water. This requires a certain amount of latent cooling but provides a dehumidification process, which is an important factor in comfortable air supply conditions.

The operating range is between 20 and 55 °C approximately and is controlled by the HP/LP-pressure switch. In relatively dry locations the air temperature drop will depend on inlet conditions.

Data

Data and dimensions on the cabinet are shown in the following table:

Specification	Designation	Value 6,0 kW
Dimensions	Height x width x depth - mm	1110 x 754 x 920 mm
Weight	kg	162
Cabinet material		0.9 mm galvanized sheet metal plates
Packaging	-	Wooden pallet and cardboard
Voltage supply	V/PH/Hz	230/1/50
Max current	Amp	16A
Airflow, evaporator, Standard setup ²)	m ³ /h	2,800
Cooling capacity, max	W	6.000
Refrigerant/Load	Type/kg	R134a/2,3
Max. refrigerant pressure	Bar	25
Operation temp. range	C°	20-55
Minimum room temperature setting	C°	20
GWP (Global Warming potential)		1430
IP		55
Locked rotor amperage (LRA)	A	46

Dimensions

Dimensions

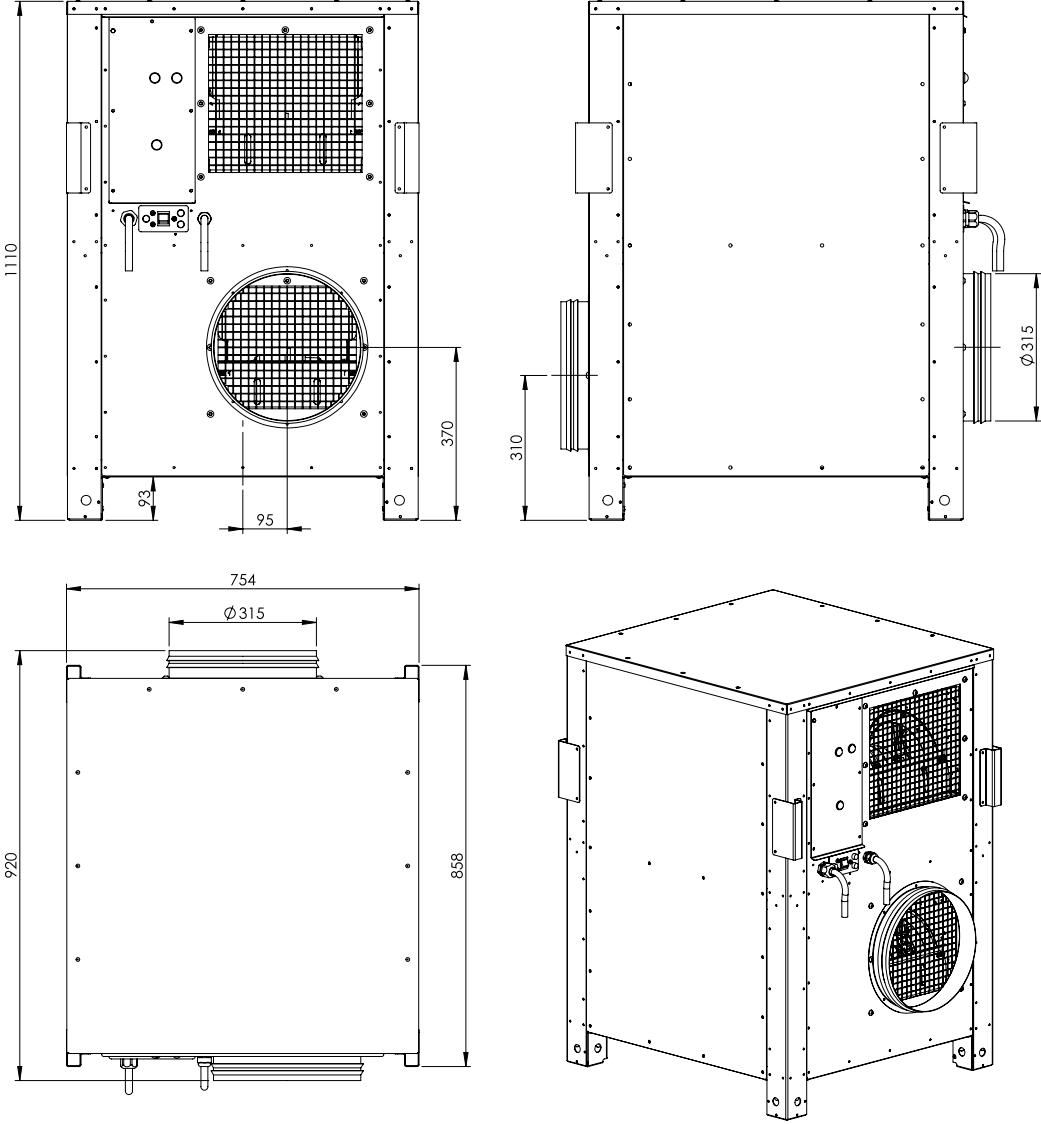

Wiring diagram

Wiring diagram

1 2 3 4 5 6 7 8 9 10 11 12 13 14 15 16 17 18 19 20 21 22 23 24 25 26 27 28 29 30 31 32 33 34 35 36 37 38

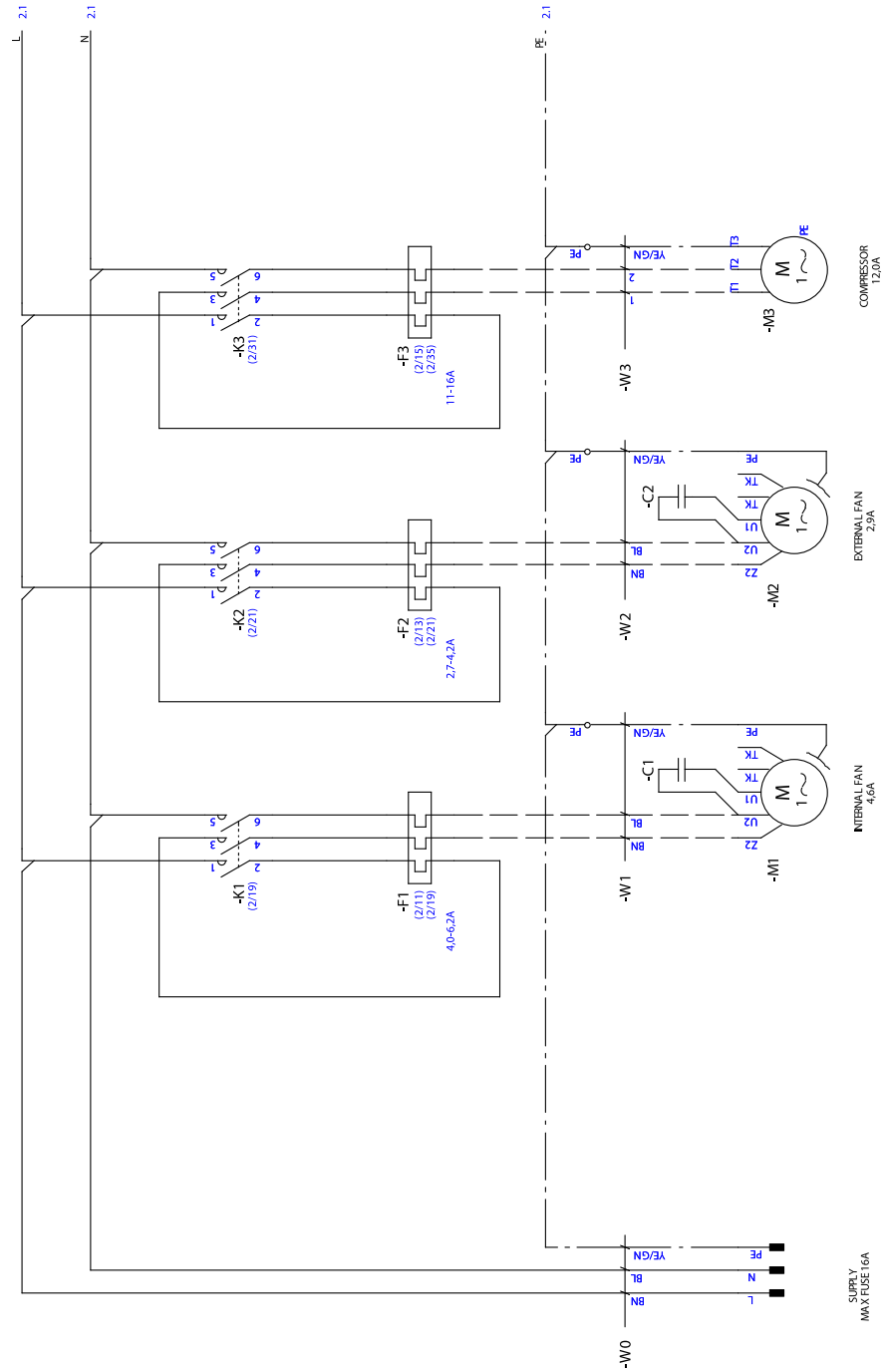

Wiring diagram, continued

Wiring diagram, Continued

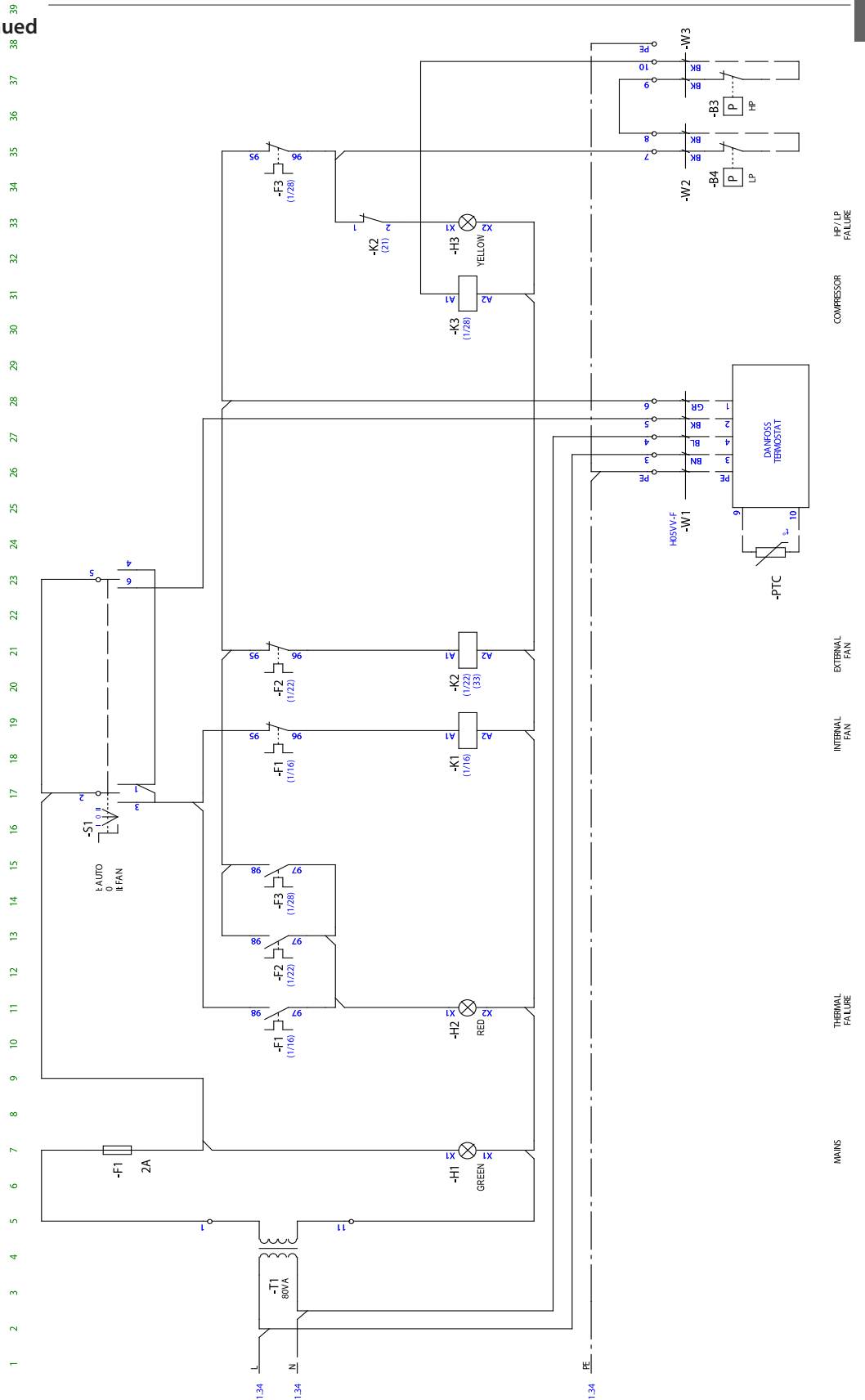

References

References

The following references refer to the wiring diagrams on the previous pages:

Reference	Description	Reference	Description
A	El. Heating coil	K1	Contacteur evaporator fan
B3	HP pressure switch	K2	Contacteur condenser fan
B4	LP pressure switch	K3	Contacteur compressor
B2	OT thermostat el. heating coil	K4	Contacteur heating coil
B1	Limit thermostat el. heating coil	K5	Timer (After run) el. heating coil
C1	Evaporator fan motor condenser	M1	Evaporator fan motor
C2	Condenser fan motor condenser	M2	Condenser fan motor
F1	Evaporator fan motor thermo relay	M3	Compressor
F2	Condenser fan motor thermo relay	RT	Room thermostat
F3	Compressor thermo relay	S1	Function switch
H1	Green lamp "Mains"	T1	Transformer
H2	Red lamp "Thermo relay"	XRT	Thermostat plug
H3	Yellow lamp "HP/LP"	XT	Control current breaker



Dantherm A/S
Marienlystvej 65
7800 Skive
Denmark
support.dantherm.com



108885

Dantherm can accept no responsibility for possible errors and changes (en)
Der tages forbehold for trykfejl og ændringer (da)
Irrtümer und Änderungen vorbehalten (de)
Dantherm n'assume aucune responsabilité pour erreurs et modifications éventuelles (fr)

