

# Instruction Manual

---

Soundbox

---

Series

VP6

---



This instruction manual shall not be reproduced, copied and distributed, neither in parts nor completely, without the manufacturer's written permit.

All rights reserved.

The instruction manual is based on the technical and product-specific parameters. The manufacturer reserves the right to add supplementary information to the instruction manual.

Using a device outside the specified conditions and contrary to its designated use will lead to the forfeiture of all warranty claims.

As of: 06\_2018

---

<b>1</b>	<b>Notes on this instruction manual</b>	<b>2</b>
	Target groups	2
	Conventions	2
	Designated use	3
<b>2</b>	<b>Safety</b>	<b>3</b>
	Safety devices	3
	Hazards from accessories	3
	Authorised operator	3
	User	4
	Safety instructions	4
<b>3</b>	<b>Construction</b>	<b>5</b>
<b>4</b>	<b>Transport and installation</b>	<b>6</b>
	Transport	6
	Scope of delivery	7
	Operating conditions	7
	Installation	7
<b>5</b>	<b>Operation and operator control</b>	<b>9</b>
	Operating elements	9
	Selection of the motor stage	10
	Commissioning and operator control	12
<b>6</b>	<b>Maintenance and service</b>	<b>13</b>
	Maintenance work	13
<b>7</b>	<b>Troubleshooting</b>	<b>16</b>
	Fault messages	17
<b>8</b>	<b>Shutdown, storage and disposal</b>	<b>18</b>
	Shutdown	18
	Storage	18
	Disposal	18
<b>9</b>	<b>Specifications</b>	<b>19</b>
<b>10</b>	<b>EC Declaration of Conformity</b>	<b>20</b>

### 1 Notes on this instruction manual

This instruction manual is part of the product. It contains all important information on how to transport, install, operate, store and dispose of the device from **AERIAL** properly and safely. Therefore keep this instruction manual in a safe place.

#### Target groups

This instruction manual addresses the users and operators of the devices manufactured by **AERIAL**. They must have read and understood the instruction manual. The physical and psychological preconditions for proper and safety-conscious handling of the devices must always be guaranteed.

#### Conventions

##### Warnings

In this instruction manual you will find information intended to warn you of possible hazards at the beginning of a specific action.



##### Type and source of hazard

This symbol in connection with the signal word "DANGER" refers to a life-threatening situation. Failure to observe this Warning will result in serious, fatal injury.

- ➞ This arrow marks precise steps to avert danger which must always be performed.



##### Type and source of hazard

This symbol in connection with the signal word "WARNING" refers to a dangerous situation. Failure to observe this Warning can result in life-threatening injury and death.

- ➞ This arrow marks precise steps to avert danger which must be performed.



##### Type and source of hazard

This symbol in connection with the word "CAUTION" warns of minor or moderate injury and potential material damage.

- ➞ Measures to prevent personal injury or material damage are described here.



In this box you find tips and information concerning the use of the device.

## Designated use

The soundbox VP6 is designed for conveying air and non-explosive gases and gas/air mixtures as pressure or vacuum pump.

The soundbox VP6 is designed exclusively for use at atmospheric pressure. Operating the device within the limits of designated use also involves observing the specified operating conditions (refer to page 6). Any use of the device going beyond the designated use specified above is considered contrary to its designated use.

Misuse is concerned if the soundbox VP6 is used for purposes not included in designated use. In these cases the manufacturer does not assume any liability for personal and material damage.

## 2 Safety

### Safety devices

The soundbox VP6 was subjected to thorough safety testing. Improper operation or misuse will cause danger to

- the operator,
- the machine and other material property of the user,
- efficient operation of the machine.

All persons involved in the installation, commissioning, operation, maintenance and servicing of the devices must

- be properly qualified,
- closely observe the instructions set out in this manual.

### Hazards from accessories

Air hoses, power cables and air filters must be properly installed, and must not disable the protection devices of the VP6. The operating elements must always be accessible.

### Authorised operator

The soundbox VP6 may only be operated by persons commissioned and instructed by the user. In the working area the operator is responsible to third parties.

For all activities on the device the responsibilities must be clearly defined and observed.

Unclear competences are a safety risk.

### User

The user must

- make the instruction manual accessible to the operator,
- make sure that the operator has read and understood the instruction manual.

### Safety instructions

The devices must **not** be used under the following conditions:

- in rooms with potentially explosive atmospheres.
- in rooms with aggressive atmospheres, e.g. ammonia, wood acids.
- in rooms with water with a pH value outside the range from 7.0 to 7.4.
- In rooms with salt or liquids with a salt content > 1%.
- in rooms with ozone-treated air.
- in rooms with high solvent concentration.
- in rooms with extreme dust load.
- In small, closed rooms without sufficient supply and exhaust air.

In addition the following must be observed when using the soundbox VP6:

- Work on electrical equipment may only be carried out by skilled electricians.
- The cooling air has a temperature of approx. 60 °C. Please observe this during installation and handling the device. Keep sufficient distance.
- Original spare parts or spare parts approved by the manufacturer shall exclusively be used.

### 3 Construction

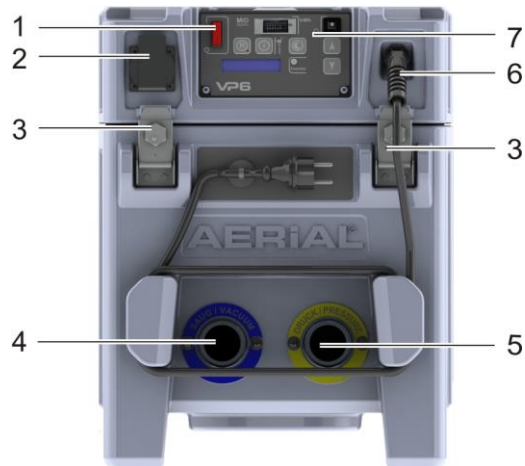

Fig. 1: AERIAL soundbox series VP6 - overview

1	On / Off switch	5	Tube connector, pressure side
2	Unit socket	6	Power cable
3	Tension lock	7	Operating panel
4	Tube connector, intake side		

The soundbox VP6 is equipped with a multi-stage adjustable turbine.  
The integrated noise stop system ensures a low noise level.

### 4 Transport and installation



#### **Risk of injury due to loss of stability**

The soundbox is heavy. Loss of stability or uncontrolled Moments may cause serious injuries and material damage.

- When moving or transporting the device always use the transport handles or recessed grips.
- Avoid incorrect or unfavourable posture.
- Always secure the soundbox against tipping.
- Always place the device on a level and firm surface.



#### **Crushing hazard from wrong handling of carrying handle**

- When moving or transporting the device always use the transport handles or recessed grips.
- Avoid uncontrolled moments.

### Transport

1. Remove the packaging material completely and dispose of according to the local regulations.
2. Check the delivery for completeness.
3. Transport the soundbox to the installation site using the carrying options provided.



### Scope of delivery

- Soundbox VP6
- One instruction manual

### Operating conditions

The soundbox VP6 is intended for use in screed and insulation layer drying and hollow space drying. It works without problems in the temperature range from 0 °C to +35 °C.



Fig. 2: Fixing points for belt system

### Installation

The devices can be stacked, and are provided with fixing points for a belt system on the right and left.

### Connection



**DANGER**

#### **Danger to life due to electric shock**

- ⇒ Prior to commissioning the technical data of the soundbox VP6 must be compared with the conditions prevailing in the room of installation!

The following items must be checked prior to electrical connection of the soundbox:

- The mains voltage must be in conformity with the voltage of the device!
- Socket outlet and supply system must be sufficiently fused!
- An RCCB must have been installed!

4. Connect the power plug of the soundbox to a suitable power outlet.

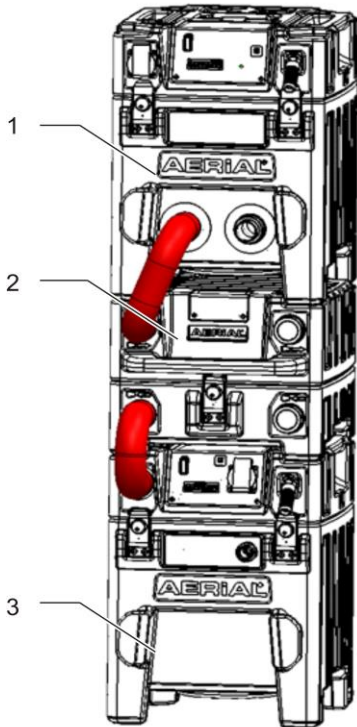

Fig. 3: Aercube with soundbox VP6 in vacuum mode

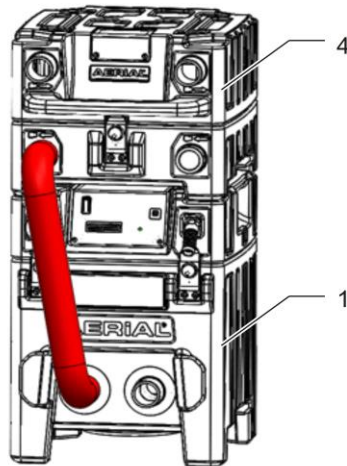

Fig. 4: Aercube with soundbox VP6 in pressure mode

1	Soundbox VP6	3	Water separator VT2
2	Hepa filter HF2	4	Sound absorber SD2 with prefilter 6005-0007 or Hepa filter HF2

The soundbox VP6 must be operated with a suitable air filter system on the intake side. We recommend to use our HF2 filter system. When operated in the vacuum mode a water separator may be necessary. In the pressure mode it must be verified that the ground conditions withstand a process air temperature of approx. 70°C.



Use tubes of 50 mm diameter for efficient drying. Smaller tubes result in high energy consumption and longer drying times.

## 5 Operation and operator control



### Danger of injury and damage to appliance

Inadmissible ambient conditions and improper operation of the device may constitute a risk.

➡ Read the instruction manual before commissioning the soundbox VP6.

### Operating elements

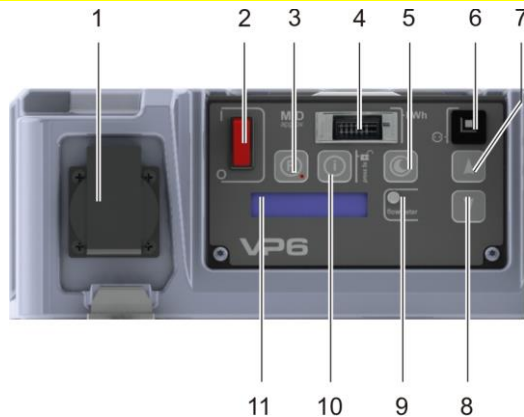

Fig. 5: Operating panel Soundbox VP6

1	Unit socket	7	Membrane key "Increase motor stage"
2	On / Off switch	8	Membrane key "Reduce motor stage"
3	Membrane key "Reset" with red LED	9	LED green, yellow, red
4	Watt meter (MID)	10	Membrane key "Info"
5	Membrane key "Night mode"	11	Display LED matrix, blue
6	Unit socket fuse		

In the standard version, the energy consumption of the units connected to the unit socket (item 1) is not counted by the calibrated watt meter (MID) (item 4). Customized solutions are possible.

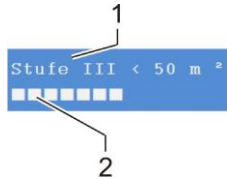

Fig. 6: Display

1	Motor stage	2	Bar diagram to display the counter-pressure
---	-------------	---	---

## Selection of the motor stage

Selection of the right motor stage is important for efficient drying.

The values in the table below relate to the room size.





Stage	Room size
1	up to 15 m <sup>2</sup>
2	up to 30 m <sup>2</sup>
3	up to 50 m <sup>2</sup>
4	up to 70 m <sup>2</sup>





The smaller the peaks in the bar graph, the more efficient is the drying process.

## Menu key "Info"

	Press briefly	Operating hours total	123456 h
	Press 1x	Display temperature and differential pressure of process air	36 C -135 bar
	Press 2x	Display version number and serial number of electronics system	V 1.0 SN:12345678





	Press briefly	Language setting	Sprache deutsch
	Keep pressed	Change language <i>DE, GB, FR, IT, S, NO, FI, NL, PL</i>	Language English
	Keep pressed	Change language <i>DE, GB, FR, IT, S, NO, FI, NL, PL</i>	Language English
	Press briefly	Save new language setting	saved

**Motor stage key "Increase motor stage"**

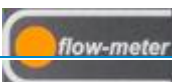

	Press briefly	Increase motor stage by one stage (highest stage: 4)	
	Press briefly	Reduce motor stage by one stage (lowest stage: 1)	

**Motor stage key "Night key"**

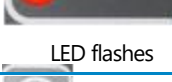
	Press briefly (function only in stages 2-4. Because counter-pressure is too high no selection possible in stage 4.)	Device runs in whisper mode. Countdown of 10 hours starts.  After repeated pressing or expiry of the 10 hours device changes to the stage selected last.	Night mode 09:59 ■■■■
---	--	---	--------------------------

Color	flow-meter display		
		Turbine in normal mode	
		Turbine at power limit	
		Turbine overloaded	

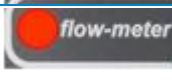
### After 15 seconds of overload:

	and		Turbine off, cooling air fan remains active
LED flashes			
		When red LED flashes	press "Reset", turbine on

## Commissioning and operator control

1. Connect the soundbox VP6 electrically, s. page 6.
2. Ensure that air tubes have been connected properly.
3. Switch on the soundbox via the On/Off switch (s. page 8, fig. 5, item 2).

The following indication appears in the display:

VP6- M  
Rev 6.0

Then the device starts and the display changes to:

Stage 2

The last motor stage adjusted starts (Autostart). If no motor stage has been saved the soundbox VP6 starts with stage 1.

## 6 Maintenance and service

### Maintenance work



#### Dust hazard

- ➔ During cleaning with compressed air dust is released into the atmosphere.
- ➔ Clean foam filter from outside and inside with a vacuum cleaner, if necessary wash and dry it.
- ➔ Clean the device with compressed air only in an open environment. Wear protective mask and goggles.



#### Danger of injury by electric shock and risk of material damage

- ➔ The device may only be repaired by trained specialised staff. Within the warranty period, any work on the soundbox shall only be carried out by the manufacturer or persons commissioned by the manufacturer.
- ➔ Work on electrical parts of the indoor air laundry dryer may only be carried out by the manufacturer or by authorised qualified electricians.



#### Danger of injury from the rotating fan blade during maintenance

- ➔ The device may only be repaired by trained specialised staff.



#### Risk of injury from cuts caused by reaching into the grille when cleaning the filter

- ➔ Do not reach into the grille openings behind the air filter



**Danger of burns due to contact with hot components of the cooling circuit and with the turbine respectively the channel compressor**

- ➔ Repairs or maintenance work may only be carried out by the manufacturer or personnel authorised by the manufacturer.



**Damage to appliance**

Cleaning agents can cause damage to surfaces.

- ➔ Use only mild detergents.

The cleaning intervals depend largely on the operating conditions. Therefore check your soundbox after each drying operation.

In order to guarantee trouble-free functioning of the device it must be cleaned at regular intervals, and in particular the air filter must be checked for soiling and damage. Proceed as follows:

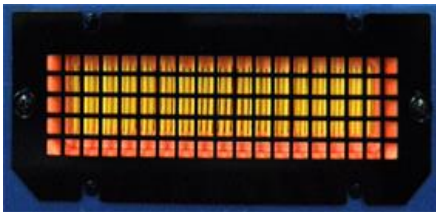

Fig. 7: Air filter on rear side



Fig. 8: Air filter change

- Remove the filter grille by loosening the two screws (see fig. 6). Replace, if required.
- Insert new or cleaned filter. Use only original filters to guarantee proper functioning of the soundbox VP6.





Fig. 9: Coarse filter intake socket

- Visual inspection: Coarse filter (see fig. 8, arrow) in intake socket. If the coarse filter is soiled turn out the intake socket and clean the filter.
- Clean casing on the outside with a moist cloth.

### 7 Troubleshooting

If problems arise with the soundbox VP6 please check the following points. Should the fault not be located please contact your technical advisor.



#### **Danger of injury by electric shock and risk of material damage**

- ↻ The device may only be repaired by trained specialised staff. Within the warranty period, any work on the soundbox shall only be carried out by the manufacturer or persons commissioned by the manufacturer.
- ↻ Work on electrical parts of the indoor air laundry dryer may only be carried out by the manufacturer or by authorised qualified electricians.



#### **Danger of injury from the rotating fan blade during maintenance**

- ↻ The device may only be repaired by trained specialised staff..



#### **Danger of burns due to contact with hot components inside the soundbox**



- ↻ Repairs or maintenance work may only be carried out by the manufacturer or personnel authorised by the manufacturer.



#### **Danger of burns due to contact with hot components of the cooling circuit and with the turbine respectively the channel compressor**

- ↻ Repairs or maintenance work may only be carried out by the manufacturer or personnel authorised by the manufacturer.

## Fault messages

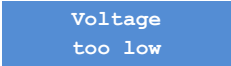
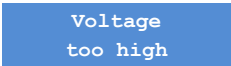
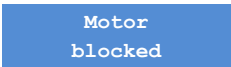
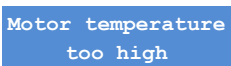
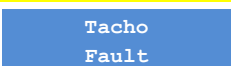
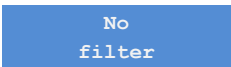
Display	Meaning	Remedy
	Device overloaded, Indicator flashes	Remove the cause of the overload.
	LED in Reset button flashes red	Check the tube connections, the device filter, connected filters. Replace clogged filters by new ones.
	LED flashes red.	Press the Reset button.
	Voltage too low	Turbine switches automatically off Contact the Aerial Service
	Voltage too high	Turbine switches automatically off Contact the Aerial Service
	Motor blocked	Turbine switches automatically off Contact the Aerial Service
	Motor temperature too high	Let device cool down to room temperature, and re-start it via the On/Off switch.
	Turbine turns too fast	Turbine switches automatically off Check whether air is fed or drawn into the VP6.
	Air filter for cooling air not present or mounted incorrectly	see chapter 6, page 13

### 8 Shutdown, storage and disposal

#### Shutdown

If you do not need the soundbox VP6 for a longer period of time you can shut it down for some time. To do so proceed as follows:

1. Switch off the soundbox via the On/Off switch  
(page 5, Fig. 1, item 1).
2. Pull the power plug.

#### Storage

Store the soundbox VP6 in conformity with the specified safety instructions (see page 4).

#### Disposal

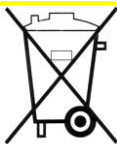

Please do not dispose of this device with the domestic waste.  
Dispose of the device in accordance with the legal regulations.

---

## 9 Specifications

General data		
Power supply	230 V/50 Hz	
Protection class	IP 44	
Fusing	RCCB to be installed by user	
Operating conditions	0 °C to +35 °C	
Type	Unit	VP6
Volume flow rate (free-blowing)	m <sup>3</sup> /h	Step 1: 80 Step 2: 140 Step 3: 190 Step 4: 250
Max. overpressure	mbar	270
Max. negative pressure	mbar	220
Power consumption	watt max.	1280
Noise level measured at a distance of 1 m	dB (A)	Standard mode: 61 dB(A) Night mode: 56 dB(A)
Noise level measured at a distance of 3 m	dB (A)	Standard mode: 57 dB(A) Night mode: 54 dB(A)
Dimensions H x W x D	mm	507/390/455
Weight	kg	15
Power cable length	m	4.5

## 10 EC Declaration of Conformity

### EC declaration of conformity

according to the EU Machinery Directive 2006/42/EC, Annex II 1. A

---

#### Manufacturer

Dantherm GmbH  
Oststrasse 148  
D - 22844 Norderstedt

#### Person established in the Community authorised to compile the relevant technical documentation

Manfred Föhlisch  
Dantherm GmbH  
Oststrasse 148  
D - 22844 Norderstedt

#### Description and identification of the machinery

Product / Article	Soundbox
Type	VP-6
Project number	Aerial VP-6
Funktion	<p>The soundboxe VP-6 is designed for conveying air and non-explosive gases and gas/air mixtures as pressure or vacuum pump.</p> <p>The soundbox VP6 is designed exclusively for use at atmospheric pressure. Operating the device within the limits of designated use also involves observing the specified operating conditions. Any use of the device going beyond the designated use specified above is considered contrary to its designated use.</p>

#### It is expressly declared that the machinery fulfils all relevant provisions of the following EU Directives or Regulations:

2006/42/EG	Directive 2006/42/EC of the European Parliament and of the Council of 17 May 2006 on machinery, and amending Directive 95/16/EC (recast) (1) Published in L 157/24 of 09.06.2006
2014/35/EU	Directive 2014/35/EU of the European Parliament and of the Council of 26 February 2014 on the harmonisation of the laws of the Member States relating to the making available on the market of electrical equipment designed for use within certain voltage limits Published in L 96/357 of 29.03.2014

2014/30/EU

Directive 2014/30/EU of the European Parliament and of the Council of 26 February 2014 on the harmonisation of the laws of the Member States relating to electromagnetic compatibility (recast)  
Published in L 96/79 of 29.03.2014

**Reference to the harmonised standards used, as referred to in Article 7 (2):**

EN ISO 12100:2010-11	Safety of machinery - General principles for design - Risk assessment and risk reduction (ISO 12100:2010)
EN 60204-1:2006/A1:2009	Safety of machinery - Electrical equipment of machines - Part 1: General requirements
EN 60335-1:2012/AC:2014	Household and similar electrical appliances - Safety - Part 1: General requirements IEC 60335-1:2010 (Modified)
EN 60335-1:2012/A11:2014	Household and similar electrical appliances - Safety - Part 1: General requirements IEC 60335-1:2010 (Modified)

Norderstedt, 08.06.2018

.....  
Place, Date



.....  
Signature

Manfred Föhlich

CE

Dealer stamp:

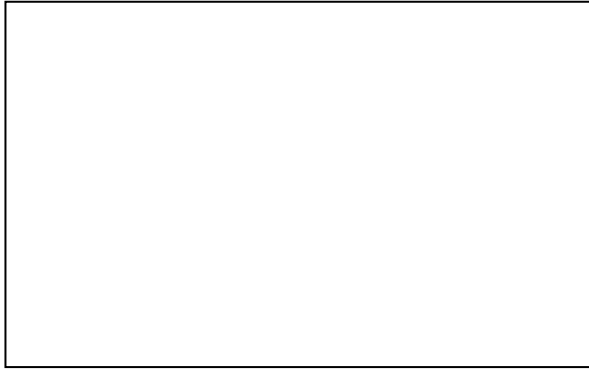

**AERIAL<sup>®</sup>**

Dantherm GmbH · Systeme zur Luftbehandlung Oststraße 148 ·  
D-22844 Norderstedt

Phone 0049 (0) 40 526 879 0 · Telefax 526 879 20

E-Mail: [info.de@dantherm.com](mailto:info.de@dantherm.com) · Internet: [www.aerial.de](http://www.aerial.de)